

AM/FM STEREO RECEIVER

SX-950

KCU

<ART-155-0>

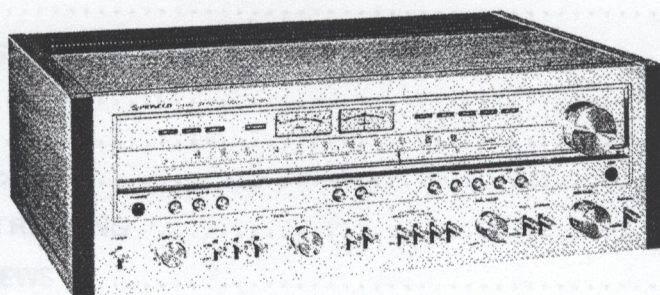

 **PIONEER®**

AM/FM STEREO RECEIVER

SX-950

KCU

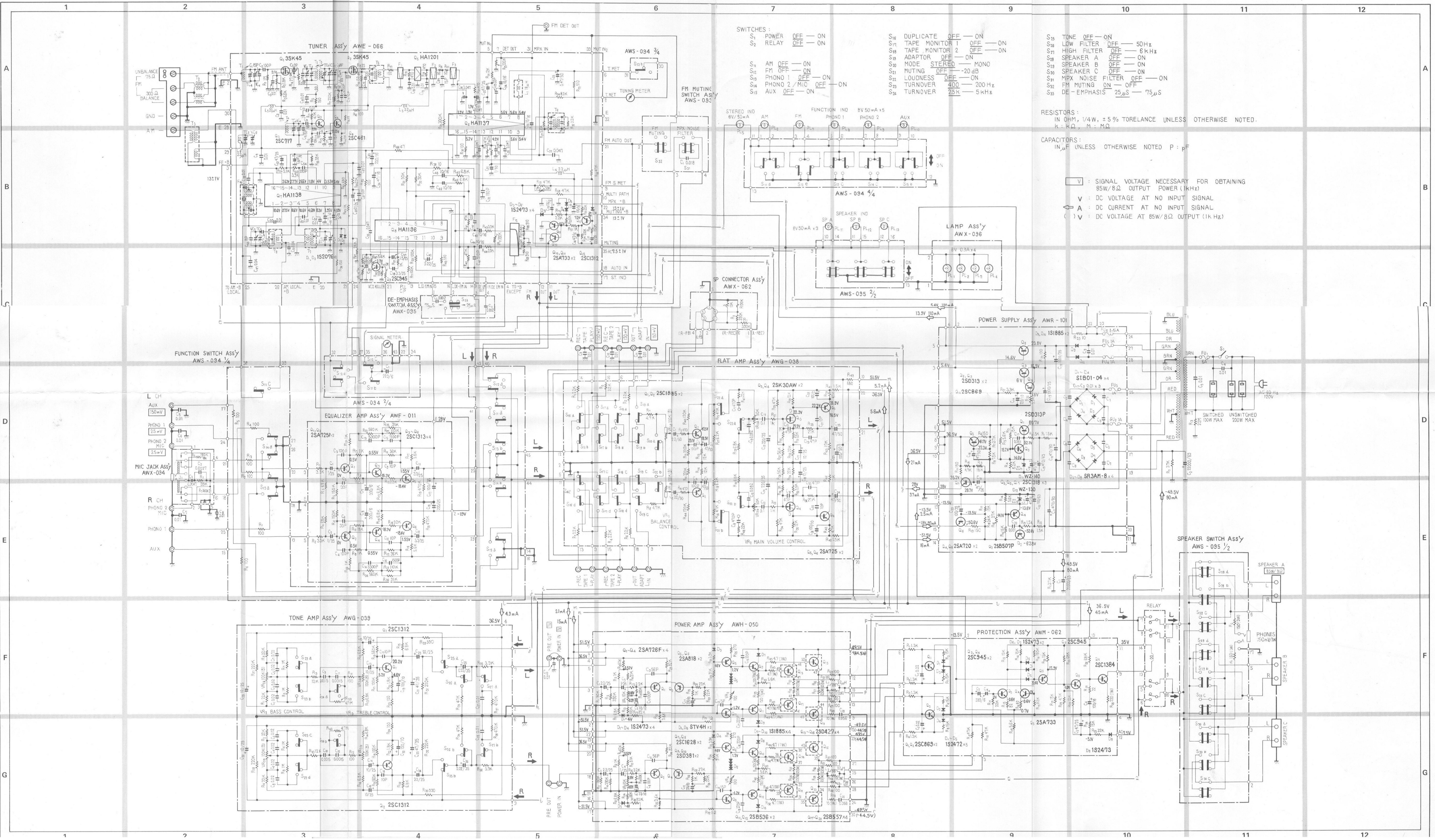

- SWITCHES:
- S₁ POWER OFF — ON
 - S₂ RELAY OFF — ON
 - S₃ AM OFF — ON
 - S₄ FM OFF — ON
 - S₅ PHONO 1 OFF — ON
 - S₆ PHONO 2 / MIC OFF — ON
 - S₇ AUX OFF — ON
 - S₈ DUPLICATE OFF — ON
 - S₉ TAPE MONITOR 1 OFF — ON
 - S₁₀ TAPE MONITOR 2 OFF — ON
 - S₁₁ ADAPTOR OFF — ON
 - S₁₂ MODE STEREO — MONO
 - S₁₃ MUTING OFF — 20 dB
 - S₁₄ LOUDNESS OFF — ON
 - S₁₅ TURNOVER 400 — 200 Hz
 - S₁₆ TURNOVER 25K — 5K Hz
 - S₁₇ TONE OFF — ON
 - S₁₈ LOW FILTER OFF — 50 Hz
 - S₁₉ HIGH FILTER OFF — 6 kHz
 - S₂₀ SPEAKER A OFF — ON
 - S₂₁ SPEAKER B OFF — ON
 - S₂₂ SPEAKER C OFF — ON
 - S₂₃ MPX NOISE FILTER OFF — ON
 - S₂₄ FM MUTING ON — OFF
 - S₂₅ DE-EMPHASIS 25 μS — 75 μS

RESISTORS:
IN OHM, 1/4W, ±5% TOLERANCE UNLESS OTHERWISE NOTED.
K: KΩ, M: MΩ

CAPACITORS:
IN μF UNLESS OTHERWISE NOTED P: pF

V: SIGNAL VOLTAGE NECESSARY FOR OBTAINING 85W/8Ω OUTPUT POWER (1KHz)
V: DC VOLTAGE AT NO INPUT SIGNAL
A: DC CURRENT AT NO INPUT SIGNAL
V: DC VOLTAGE AT 85W/8Ω OUTPUT (1KHz)

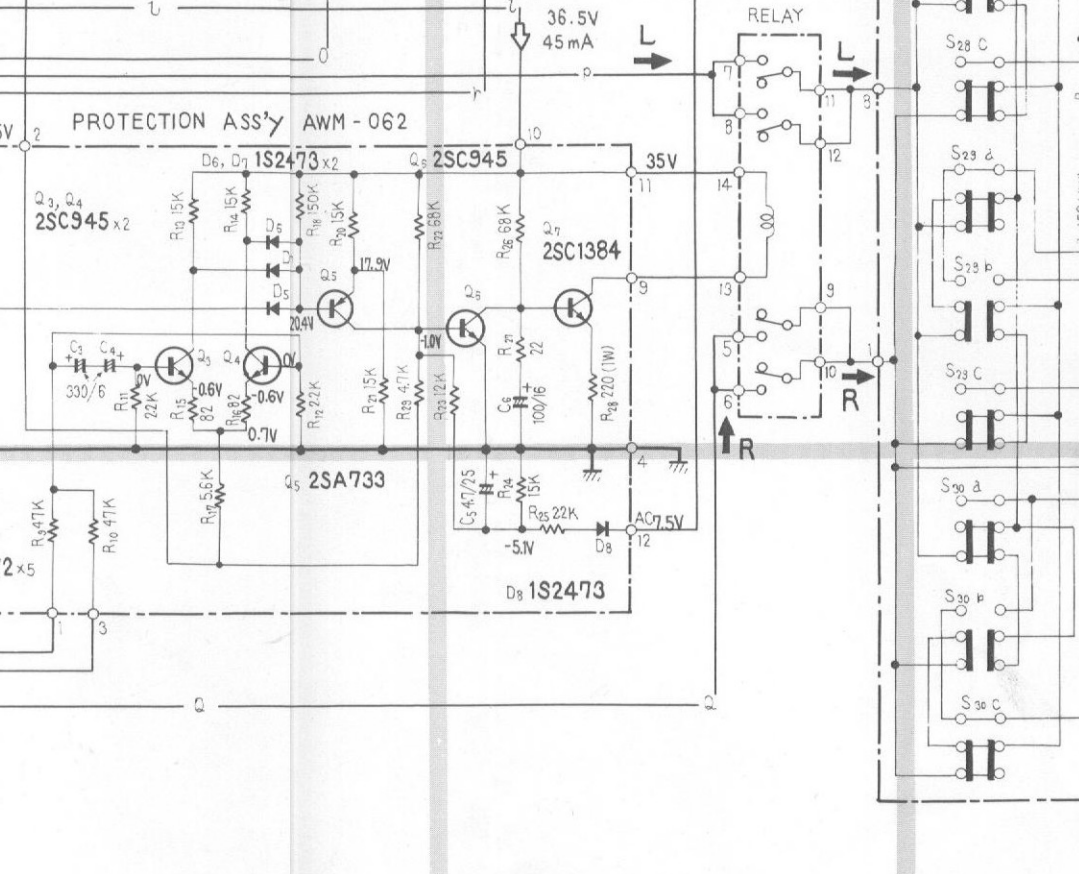
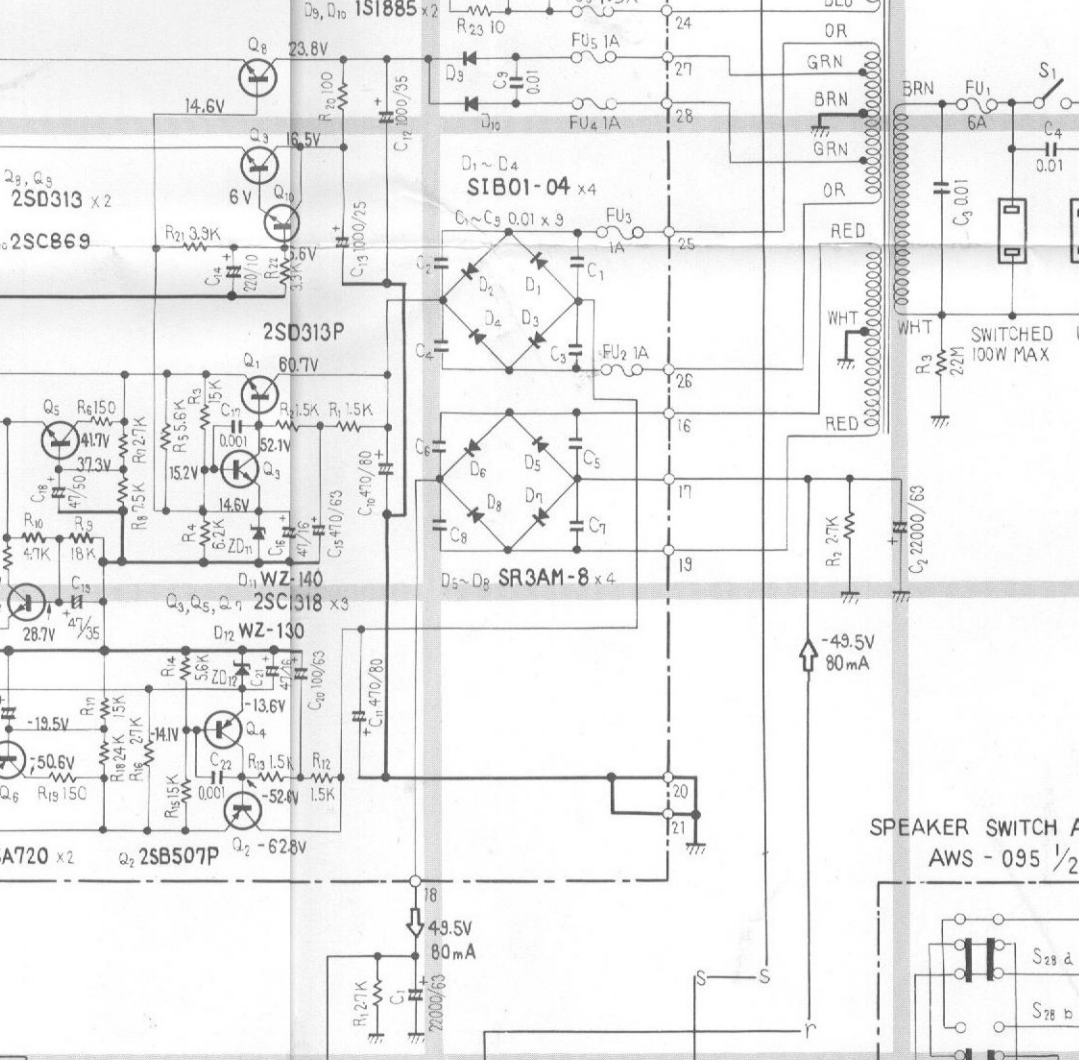
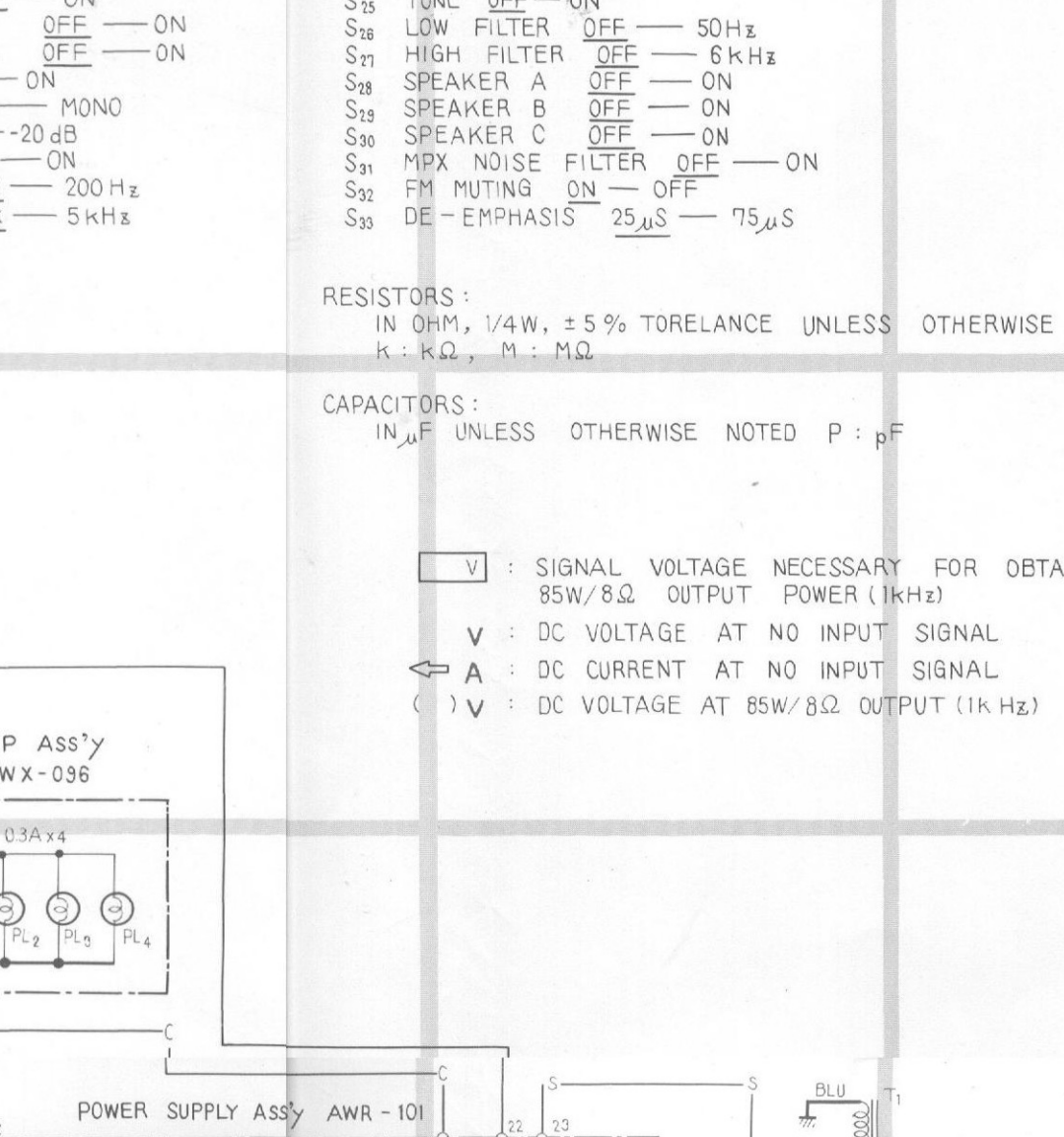
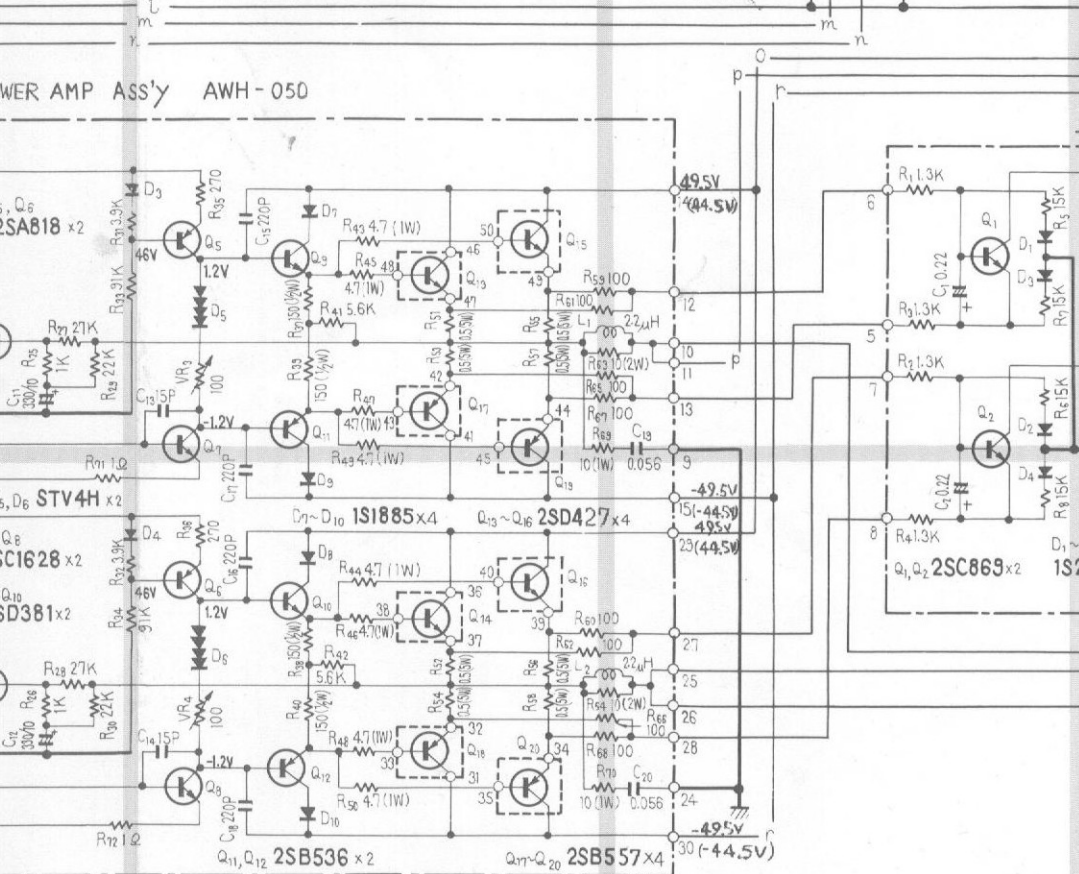
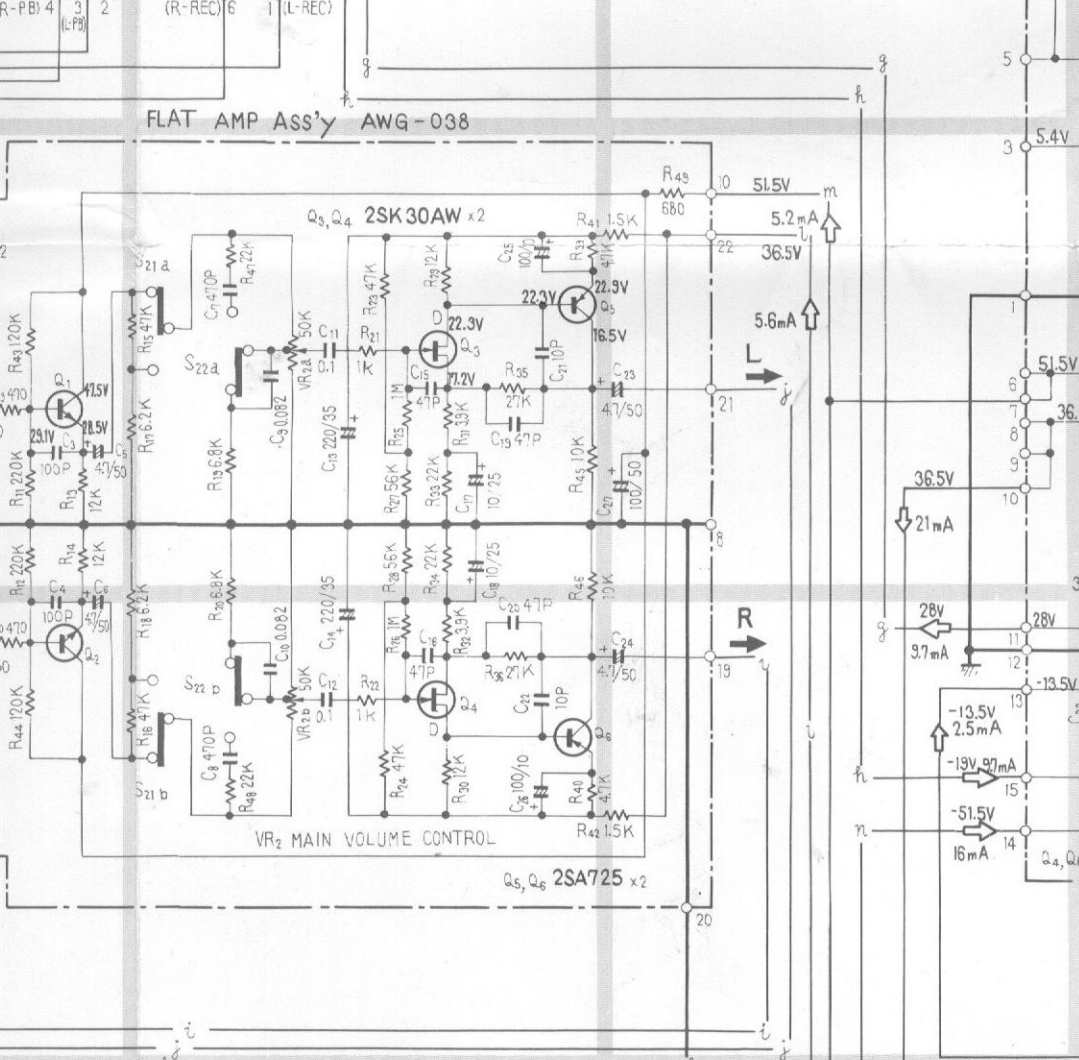
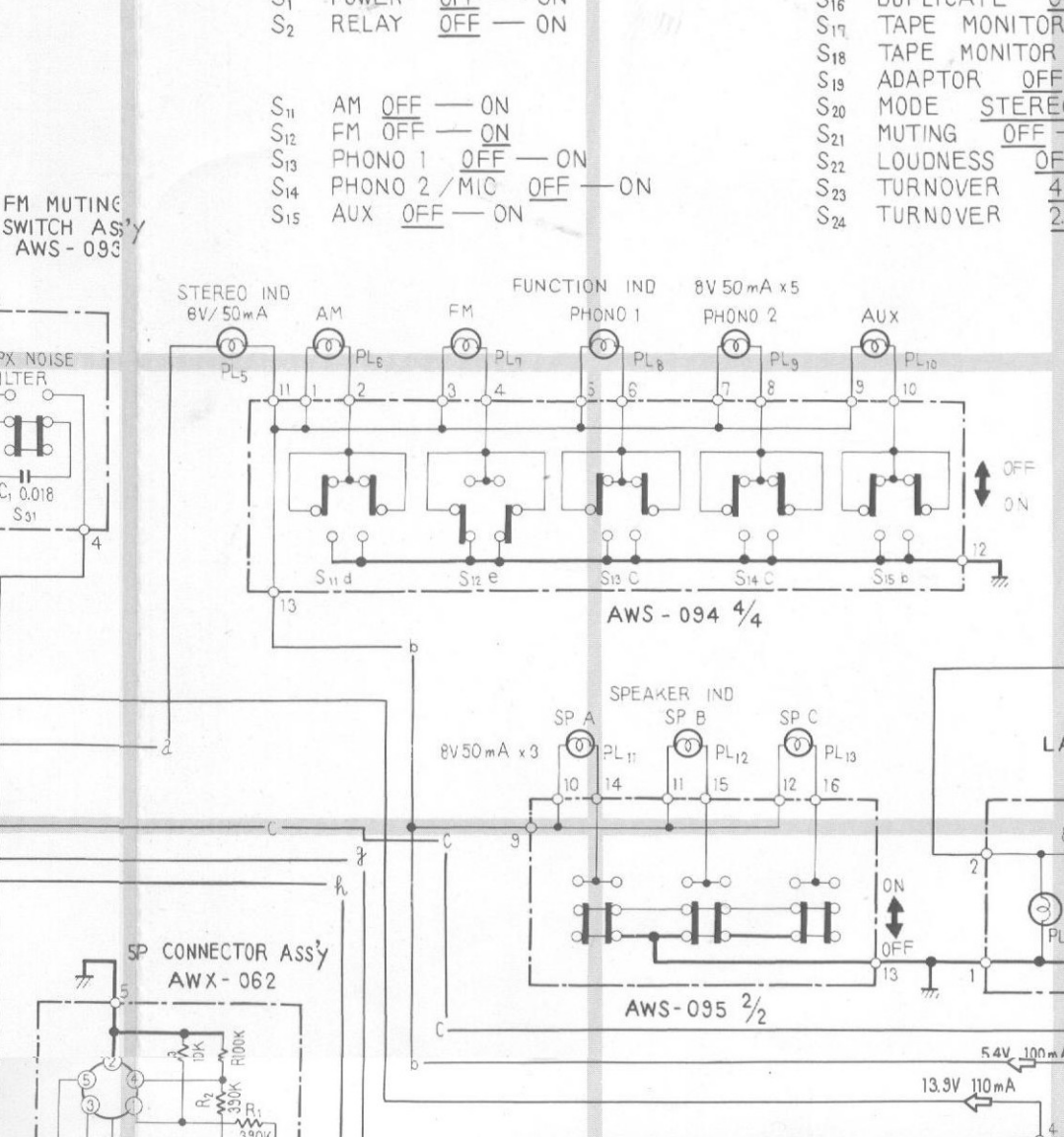
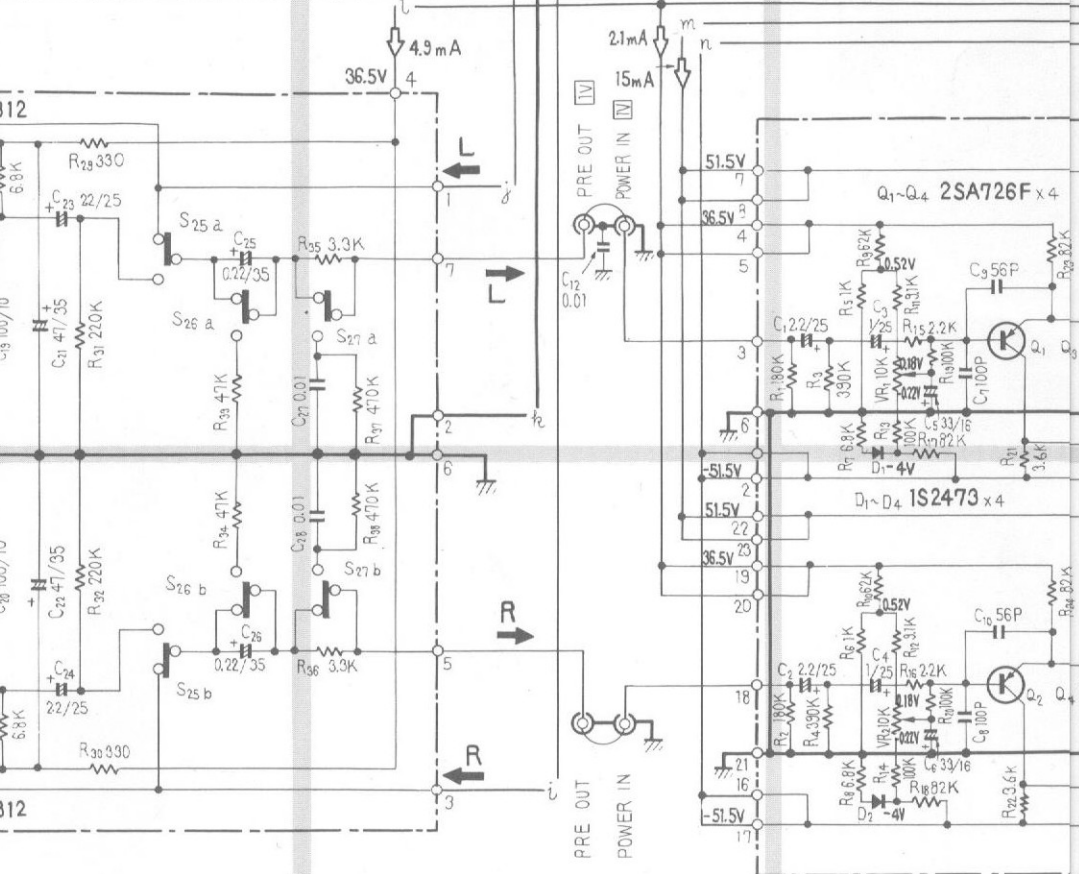
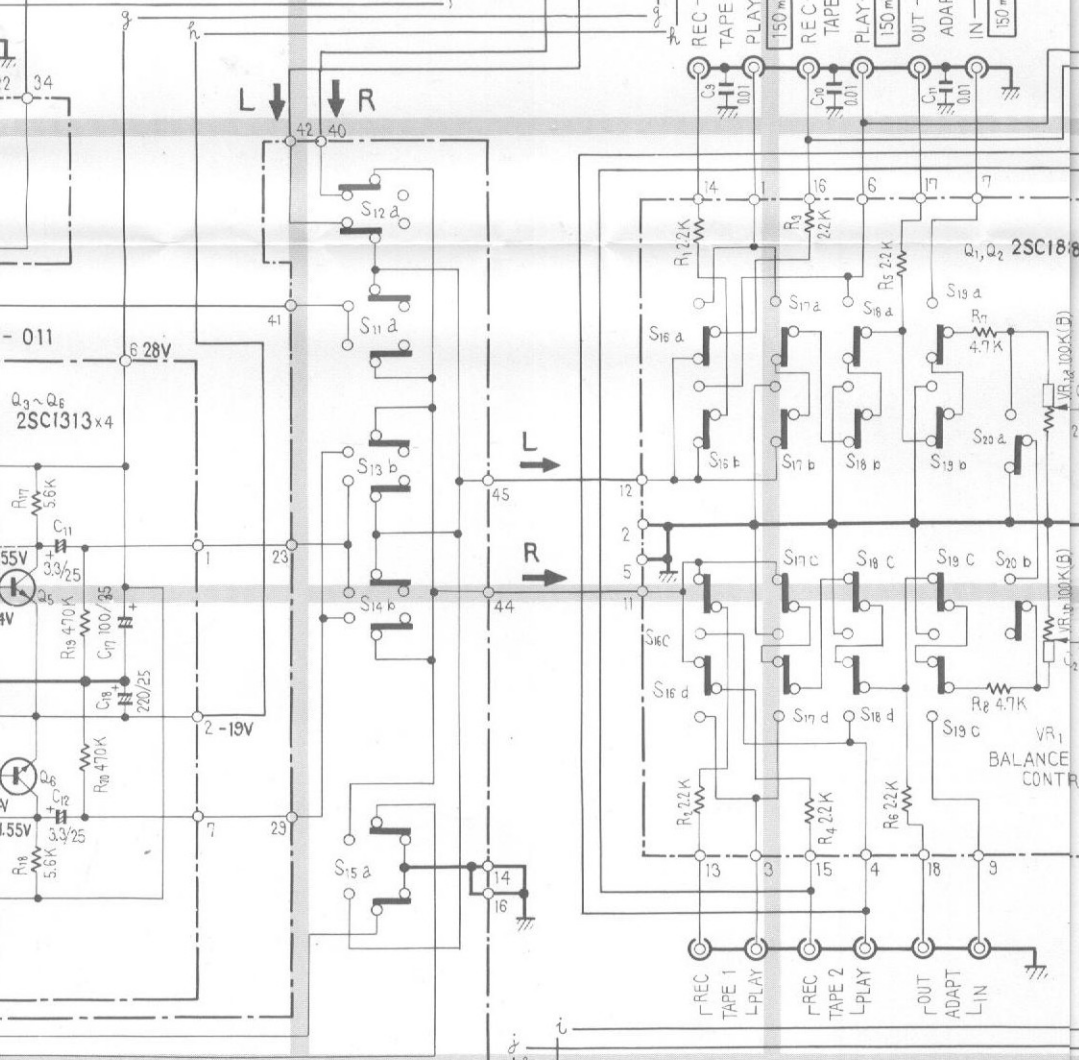
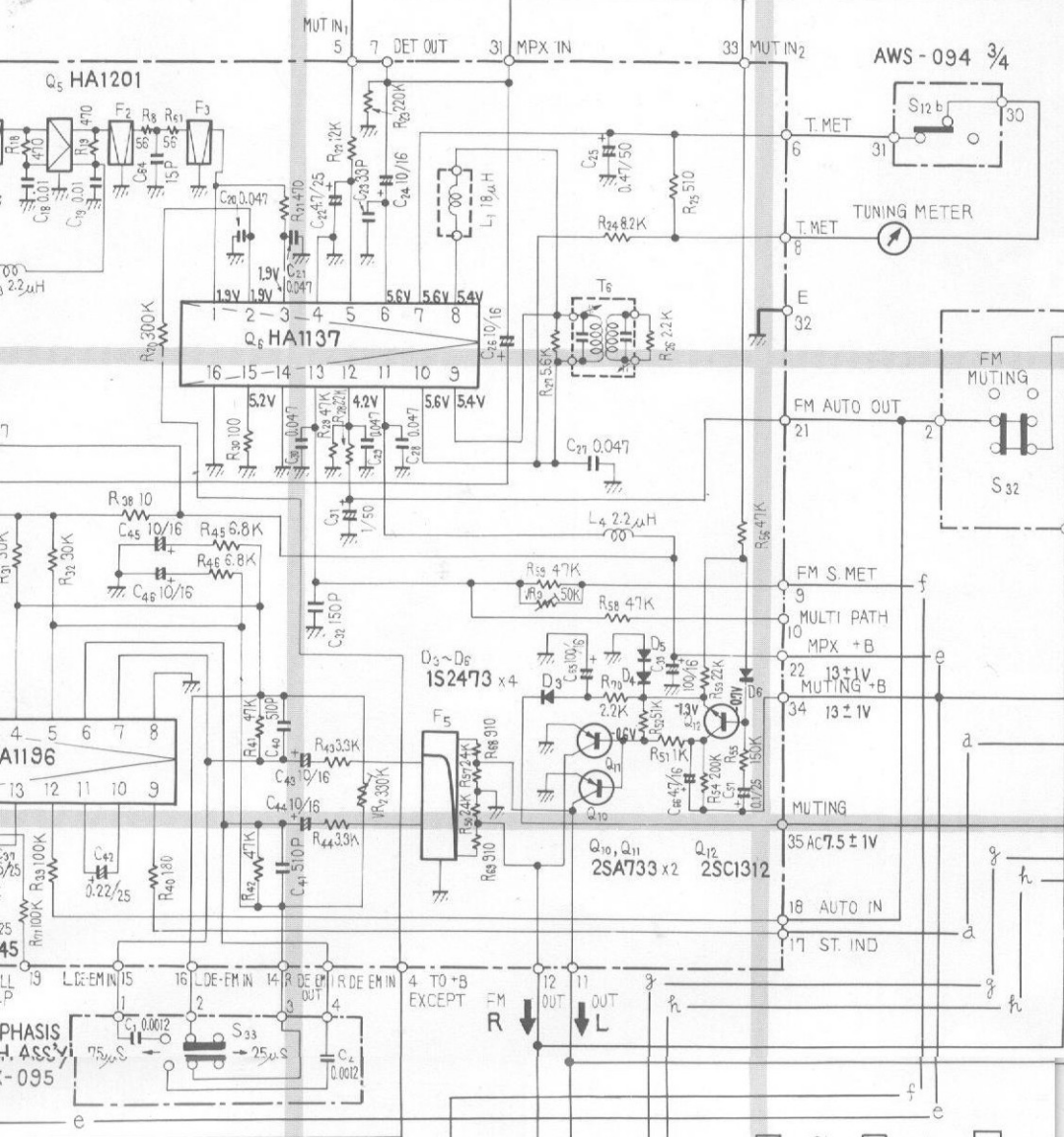
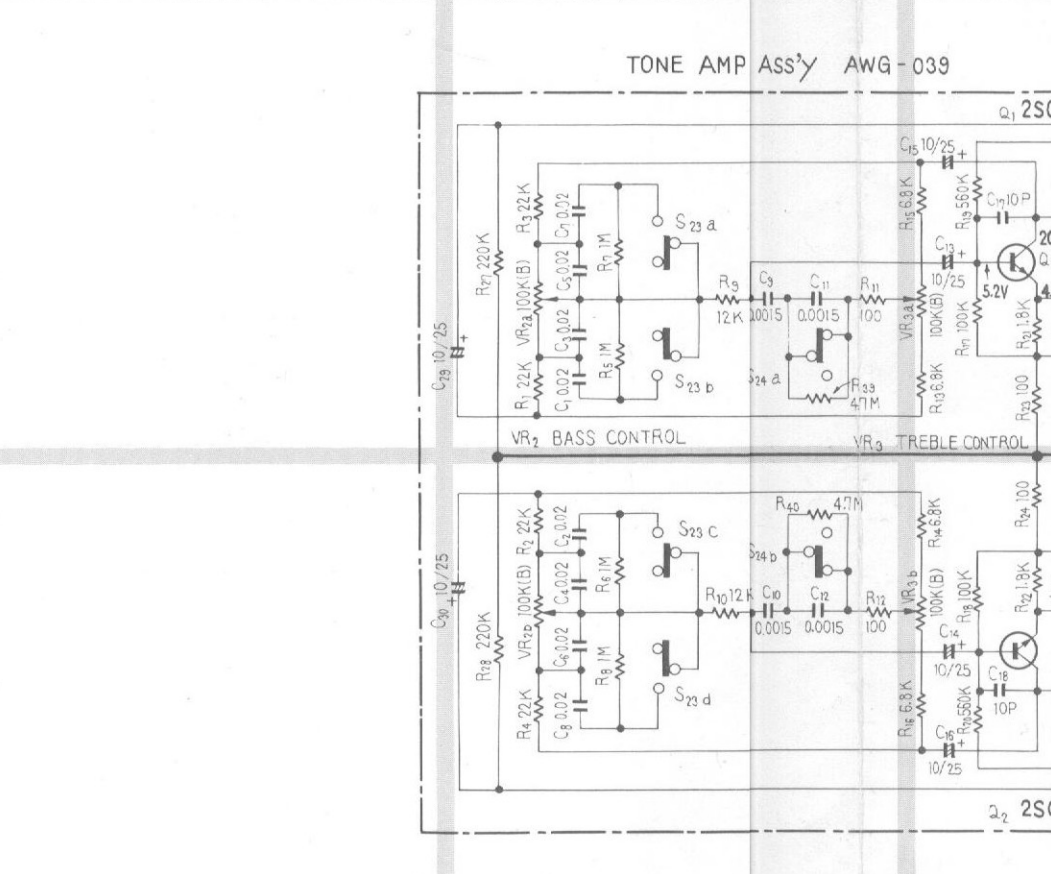
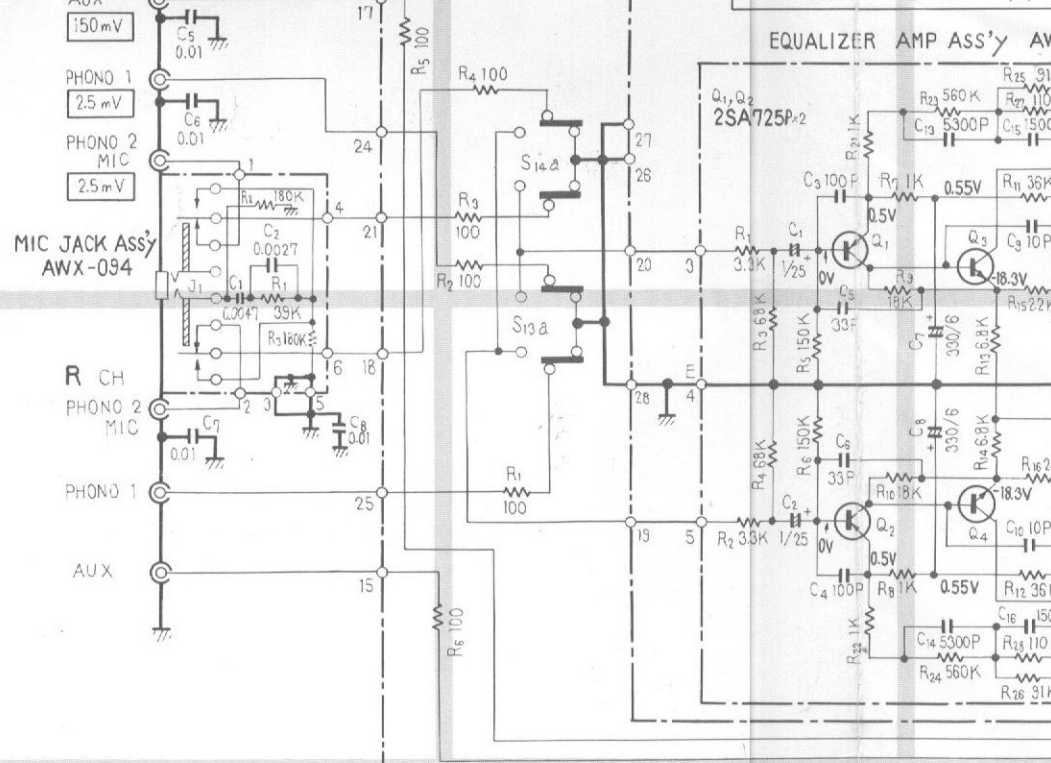
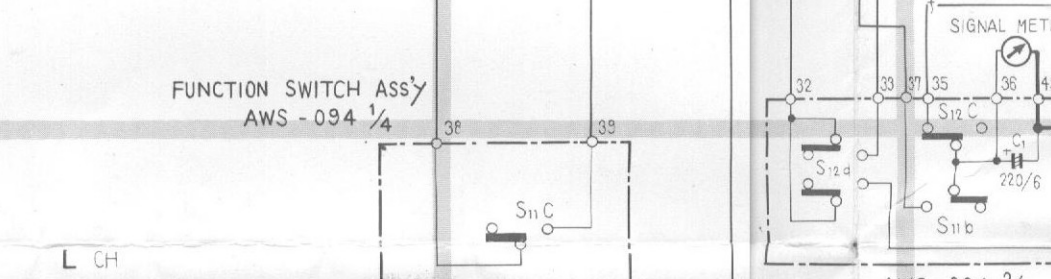
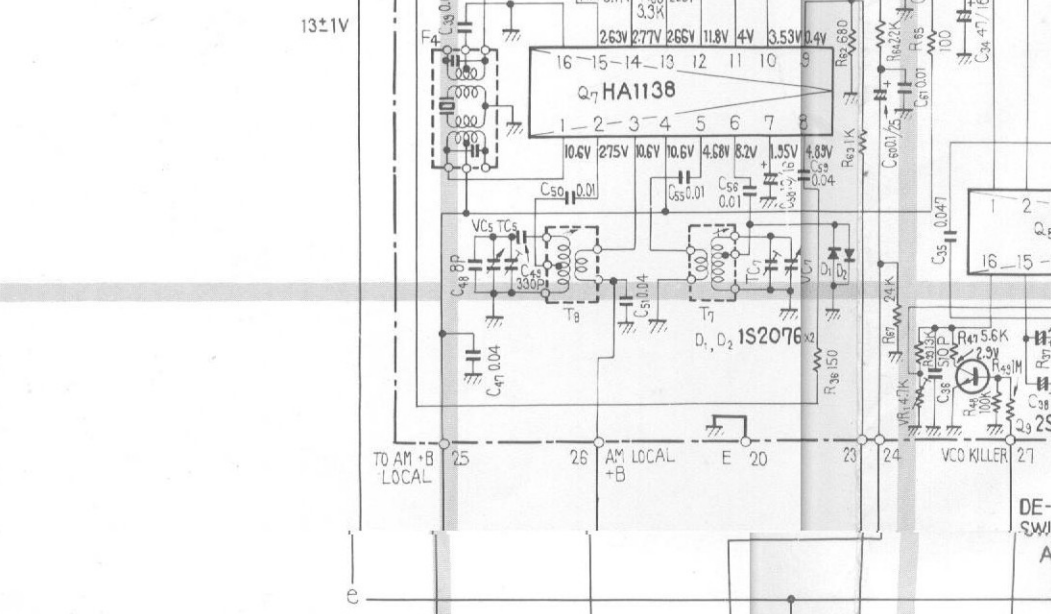
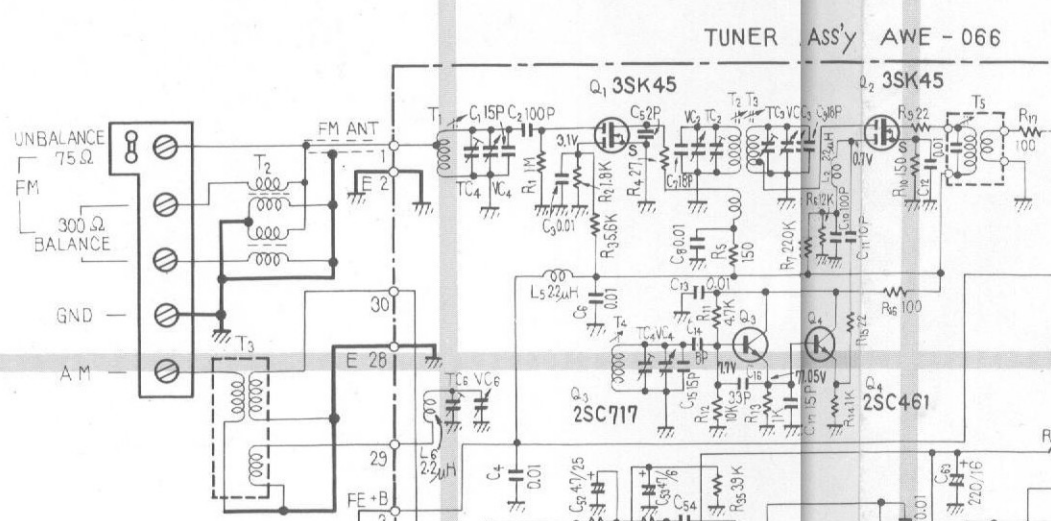

CONTENTS

1.	SPECIFICATIONS	5
2.	FRONT PANEL FACILITIES	7
3.	CONNECTION DIAGRAM	9
4.	BLOCK DIAGRAM	11
5.	CIRCUIT DESCRIPTIONS	
5.1	FM Tuner	13
5.2	AM Tuner	15
5.3	Equalizer Amplifier	16
5.4	Control Section	17
5.5	Power Amplifier	19
5.6	Protection Circuit	19
5.7	Power Supply	21
6.	LEVEL DIAGRAM	22
7.	DISASSEMBLY	23
8.	PARTS LOCATIONS	
8.1	Front Panel View	25
8.2	Front View with Panel Removed	27
8.3	Top View	29
8.4	Bottom View	31
8.5	Rear View	33
9.	ADJUSTMENTS	
9.1	AM Tuner	35
9.2	FM Tuner	36
9.3	Power Amplifier	38
10.	DIAL CORD STRINGING	39
11.	EXPLODED VIEWS	40
12.	SCHEMATIC DIAGRAMS, P.C. BOARD PATTERNS AND PARTS LISTS	
12.1	Miscellaneous-parts	48
12.2	Schematic Diagram	49
12.3	Tuner Assembly (AWE-066)	53
12.4	Microphone Jack Assembly (AWX-094)	59
12.5	Equalizer Amplifier Assembly (AWF-011)	60
12.6	5P Connector Assembly (AWX-062)	63
12.7	Switch Assembly (AWS-094)	64
12.8	Flat Amplifier Assembly (AWG-038)	67

12.9	Switch Assembly (AWS-093)	71
12.10	Tone Amplifier Assembly (AWG-039)	72
12.11	Switch Assembly (AWX-095)	75
12.12	Power Amplifier Assembly (AWH-050)	76
12.13	Protection Circuit Assembly (AWM-062)	81
12.14	Power Supply Assembly (AWR-101)	84
12.15	Switch Assembly (AWS-095)	88
13.	PACKING	90
14.	PARTS LIST OF EXPLODED VIEWS	91

1. SPECIFICATIONS

Semiconductors

FETs	4
ICs	4
Transistors	55
Diodes	36

Power Amplifier Section

Continuous Power Output from 20 Hertz to 20,000 Hertz
(Both channels driven). . . 85 watts per channel (8 ohms)
110 watts per channel (4 ohms)

Total Harmonic Distortion

(20 Hertz to 20,000 Hertz, from AUX)
Continuous Rated Power Output . . . No more than 0.1%
43 watts per channel power
output, 8 ohms No more than 0.05%
1 watt per channel power
output, 8 ohms No more than 0.05%

Intermodulation Distortion

(50 Hertz: 7,000Hertz=4:1, from AUX)
Continuous Rated Power Output . . . No more than 0.1%
43 watts per channel power
output, 8 ohms No more than 0.05%
1 watt per channel power
output, 8 ohms No more than 0.05%

Frequency Response 7Hz to 90,000Hz ± 1 dB

Input Sensitivity/Impedance

POWER AMP IN 1 V/50k ohms

Output

Speaker A, B, C, A+B, B+C, A+C
Headphone Low Impedance

Damping Factor

(20Hz to 20,000Hz, 8 ohms) 25

Hum and Noise (IHF, short-circuited, A Network) . . 100dB

Preamplifier Section

Input Sensitivity/Impedance

PHONO 1 2.5mV/50k ohms
PHONO 2 2.5mV/50k ohms
MIC 6.5mV/50k ohms
AUX 150mV/50k ohms
TAPE PLAY 1 150mV/50k ohms
TAPE PLAY 2 150mV/50k ohms
TAPE PLAY 2 (DIN connector) . . . 150mV/50k ohms

PHONO Overload Level (T.H.D. 0.1%)

PHONO 1 200mV (1kHz)
PHONO 2 200mV (1kHz)

Output Level/Impedance

TAPE REC 1 150mV
TAPE REC 2 150mV
TAPE REC 2 (DIN connector) 30mV/80k ohms
PRE OUT 1V/100 ohms

Total Harmonic Distortion

(20Hz to 20,000Hz 1V output). . . No more than 0.05%

Frequency Response

PHONO (RIAA equalization). 30Hz to 15,000Hz ± 0.2 dB
AUX, TAPE PLAY 15Hz to 40,000Hz ± 1 dB

Tone Control

BASS ± 7 dB/ ± 10 dB (100Hz)
Turnover Frequency 200Hz/400Hz
TREBLE ± 7 dB/ ± 10 dB (10kHz)
Turnover Frequency 5kHz/2.5kHz

Filter

LOW 30Hz (6dB/oct.)
HIGH 6kHz (6dB/oct.)

Loudness Contour (Volume control set

at -40dB position). . . . +6dB (100Hz), +3dB (10kHz)

Hum and Noise

(IHF, short-circuited, A Network, rated power)
PHONO 75dB
AUX, TAPE PLAY 90dB
Muting -20dB

FM Section

Usable Sensitivity. . . MONO . . . 10.3dBf (3.6 μ V/300 Ω)
STEREO . . 22.2dBf (14.1 μ V/300 Ω)

Usable Sensitivity (IHF '58). 1.8 μ V
50dB Quieting Sensitivity

MONO . . . 17.2dBf (8.0 μ V/300 Ω)
STEREO . . 38.0dBf (87 μ V/300 Ω)

Signal to Noise Ratio at 65dBf . MONO 72dB
STEREO 67dB

Distortion at 65dBf 100Hz . . . MONO 0.15%
STEREO 0.3%

1kHz MONO 0.15%
STEREO 0.3%

6kHz MONO 0.4%
STEREO 0.4%

Frequency Response 30Hz to 15,000Hz ± 0.2 dB

Capture Ratio 1.0dB

Alternate Channel Selectivity 80dB

Spurious Response Ratio 100dB

Image Response Ratio 85dB

IF Response Ratio 100dB

AM Suppression Ratio 55dB

Muting Threshold 14dBf (5.5 μ V/300 Ω)

Stereo Separation . . . 40dB (1kHz), 30dB (30Hz ~ 15kHz)

Subcarrier Product Ratio 62dB

SCA Rejection Ratio 62dB

Antenna Input 300 ohms balanced
75 ohms unbalanced

AM Section

Sensitivity (IHF, Ferrite antenna)	300 μ V/m
(IHF, Ext. antenna)	15 μ V
Selectivity	40dB
Signal to Noise Ratio	55dB
Image Response Ratio	65dB
IF Response Ratio	85dB
Antenna	Built-in Ferrite Loopstick Antenna

Miscellaneous

Power Requirements	120V 60Hz
Power Consumption	320W (UL) 560W (max.)
Dimensions	526.6(W)x173(H)x411.5(D) mm 20-3/4(W)x6-13/16(H)x16-3/16(D) in
Weight	19.1kg (42 lb 3 oz)

Furnished Parts

FM T-type Antenna	1
Operating Instructions	1
Hex. Wrench	1

NOTE:

Specifications and the design subject to possible modification without notice due to improvements.

2. FRONT PANEL FACILITIES

SPEAKER BUTTONS

Three sets of speaker terminals, A, B, and C, are provided on the rear panel, and the required speaker systems can be selected by depressing the SPEAKERS buttons as follows:

- A Speaker systems A operate
- B Speaker systems B operate
- C Speaker systems C operate

NOTES:

1. When any two buttons (A+B, B+C, C+A) are depressed simultaneously, the corresponding pairs of speaker systems will come into operation. However, it is not possible to operate all three speaker systems at the same time, even though all the buttons are depressed.
2. For private listening through headphones, return all the SPEAKERS buttons to the OFF (undepressed) position.

PHONES OUTPUT JACK

Accepts stereo headphones.

POWER SWITCH

After turning this switch ON there is a delay of some 3 to 6 seconds, during which time the protection circuit operates to eliminate unpleasant noise.

BASS CONTROL

Clockwise rotation gives stronger emphasis to the bass range below the turnover frequency (which is selected by the BASS TURNOVER switch), while counterclockwise rotation reduces bass response.

BASS TURNOVER SWITCH

This selects the frequency below which the bass tone control will begin to act. This "turnover" frequency can be set at 400Hz or 200Hz, to match the characteristics of the room, the program material, or your personal listening preferences.

TONE SWITCH

In the OFF (up) position, this switch causes the amplifier section to operate with a flat frequency response regardless of the tone control setting.

TREBLE TURNOVER SWITCH

This switch selects the frequency above which the treble tone control will begin to act. This "turnover" frequency can be set at 2.5kHz or 5kHz, to match the characteristics of the room, the program material, or your personal listening preferences.

TREBLE CONTROL

Clockwise rotation gives stronger emphasis to the high range above the turnover frequency (selected by the TREBLE TURNOVER switch), while counterclockwise rotation reduces high-range response.

FM TUNING METER

With the SIGNAL meter needle deflected to the right, make fine adjustment by centering the FM TUNING meter needle (indicating optimum reception).

SIGNAL METER

For AM and FM station tuning.

AM tuning: Tune for maximum deflection of the SIGNAL meter needle to the right.

FM tuning: Both the SIGNAL and FM TUNING meters work together. (see FM TUNING METER)

SPEAKER SYSTEM INDICATOR

FM STEREO INDICATOR

TUNING KNOB

Select the station and tune for optimum reception by observing the SIGNAL meter for AM stations, and both SIGNAL and TUNING meters for FM stations.

PROGRAM SOURCE INDICATOR

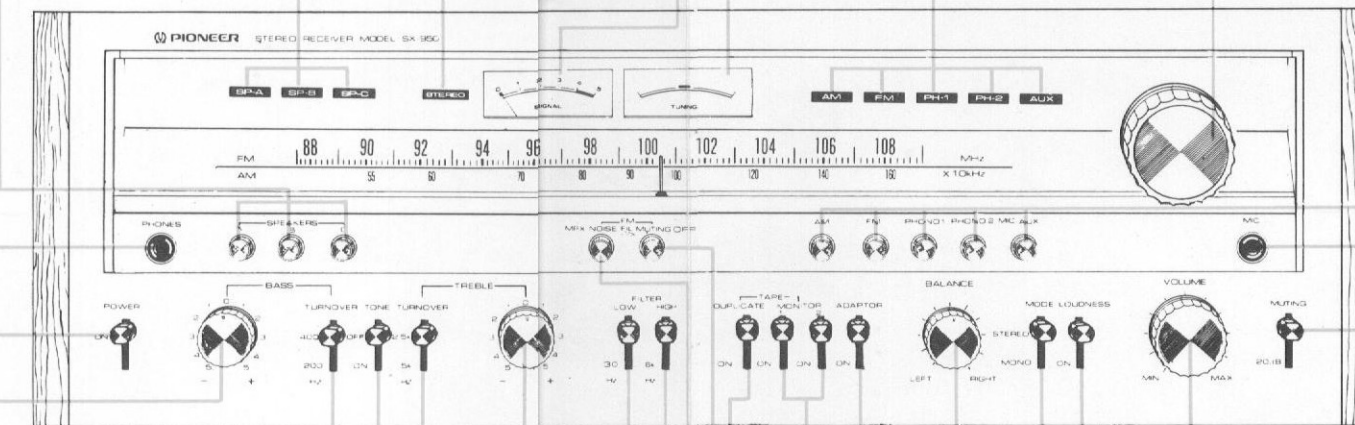

FUNCTION SELECTOR BUTTONS

To select the program source, push the buttons as follows:

- AM** For AM broadcast reception.
- FM** For FM broadcast reception. The STEREO indicator lights up when the broadcast is in stereo.
- PHONO 1** To operate a turntable connected to the PHONO 1 input jacks.
- PHONO 2/MIC** As above for PHONO 2 jacks, or for reproduction through a microphone connected to the MIC jack on the front panel. Note, when the microphone is plugged in the turntable connected to the PHONO 2 jacks cannot be used.
- AUX** For listening to an audio component (cartridge tape player, TV sound tuner, etc.) connected to the AUX input jacks.

NOTE: Only one FUNCTION button should be depressed at a time.

MIC JACK

Accepts a standard 6 ϕ mm microphone plug.

AUDIO MUTING SWITCH - 20dB

Depress this switch to attenuate the audio output by 20dB. This convenient feature saves having to disturb the VOLUME control, for example when answering the telephone.

VOLUME CONTROL

Governs the level of sound outputs both from the speaker systems and from headphones.

LOUDNESS SWITCH

Depress this switch when listening at low volume. The frequency response of the human ear varies according to the listening volume, and the depressed position compensates for hearing response by emphasizing the bass and treble.

MODE SWITCH

For stereo playback, leave this switch undepressed (or press to release, if already depressed). When depressed for MONO playback, left and right channel stereo signals will be mixed to produce monophonic sound from both speaker systems.

BALANCE CONTROL

Adjusts the balance between the sound volume from the left and right speaker systems or headphones.

ADAPTOR SWITCH

When employing adaptor components, such as a graphic equalizer adaptor, RG processor, or Dolby NR adaptor, depress this ADAPTOR switch to ON.

LOW CUT FILTER SWITCH

When low-pitched rumble (from turntable motor or other source) is obtrusive, set this switch to the 30Hz position to provide 6dB/octave attenuation at frequencies below 30Hz. If no interference is experienced, set in the up position.

HIGH CUT FILTER SWITCH

When high frequency scratch noise (from worn records or other source) is unpleasant, set this switch to the 6kHz position to provide 6dB/octave attenuation at frequencies above 6kHz. If there is no interference, set in the up position.

MPX NOISE FILTER BUTTON

Comparatively high frequency noise, incurred when receiving weak FM stereo signals, can be eliminated by depressing this button to ON. In this case however, there will be some loss of stereo separation.

TAPE MONITOR (1, 2) SWITCHES

- 1 With a tape deck connected to the TAPE 1 jacks (REC and PLAY), either playback or monitoring of a recording in progress are possible.
- 2 Same as in 1 above, with a tape deck connected to the TAPE 2 jacks (REC and PLAY):

TAPE DUPLICATE SWITCH

Set this switch in the ON (down) position to duplicate or edit a recorded tape using two tape decks.

FM MUTING BUTTON

Leave this button undepressed (in the ON position) to suppress unpleasant interstation noise while tuning between stations. Low-strength signals may also be suppressed by this function, so to pick up a weak station depress this button to the OFF position.

3. CONNECTION DIAGRAM

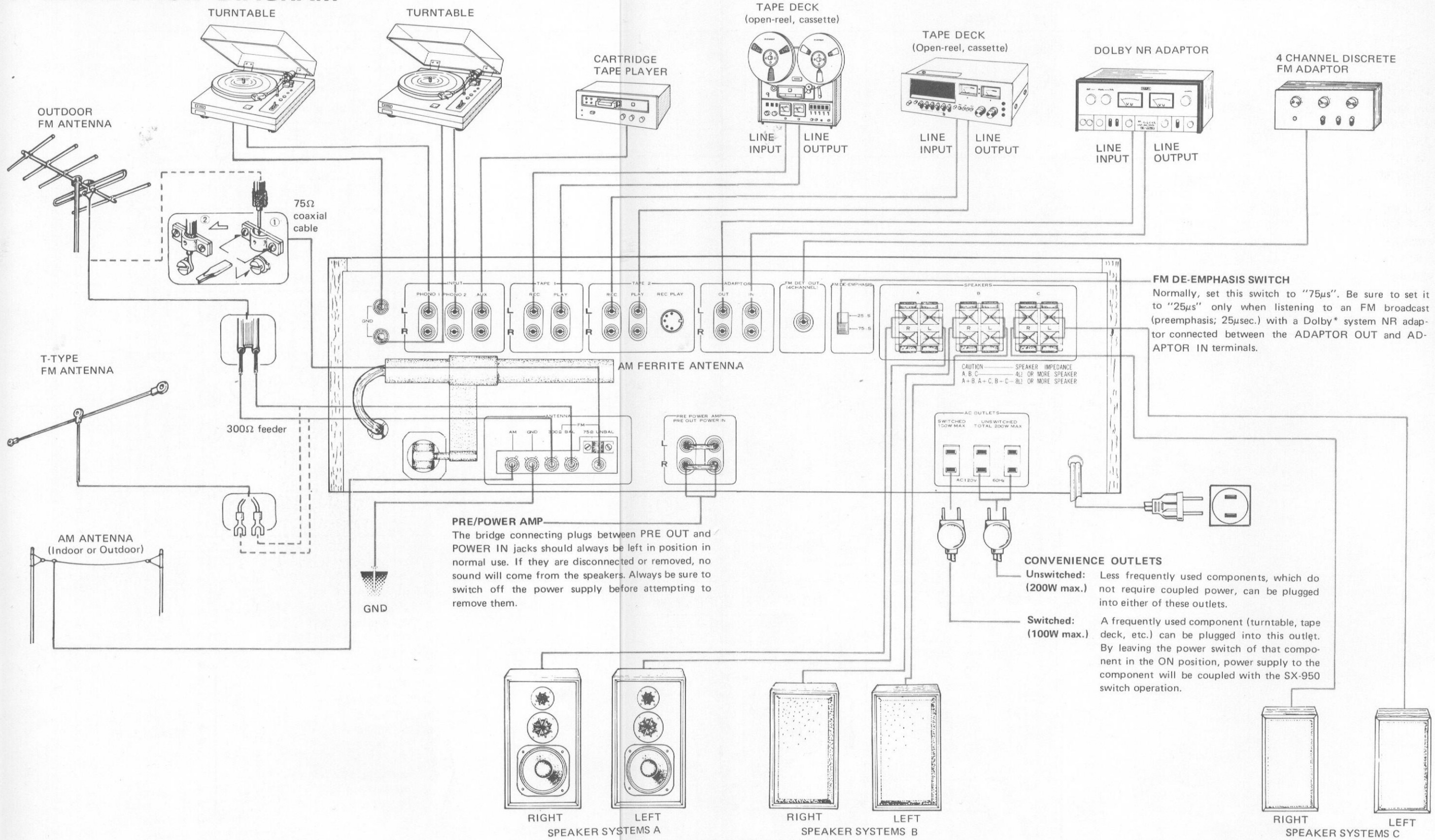

PRE/POWER AMP
 The bridge connecting plugs between PRE OUT and POWER IN jacks should always be left in position in normal use. If they are disconnected or removed, no sound will come from the speakers. Always be sure to switch off the power supply before attempting to remove them.

FM DE-EMPHASIS SWITCH
 Normally, set this switch to "75μs". Be sure to set it to "25μs" only when listening to an FM broadcast (preemphasis; 25μsec.) with a Dolby* system NR adaptor connected between the ADAPTOR OUT and ADAPTOR IN terminals.

CONVENIENCE OUTLETS
Unswitched: (200W max.) Less frequently used components, which do not require coupled power, can be plugged into either of these outlets.
Switched: (100W max.) A frequently used component (turntable, tape deck, etc.) can be plugged into this outlet. By leaving the power switch of that component in the ON position, power supply to the component will be coupled with the SX-950 switch operation.

* The word "Dolby" is a trademark of Dolby Laboratories Inc.

4. BLOCK DIAGRAM

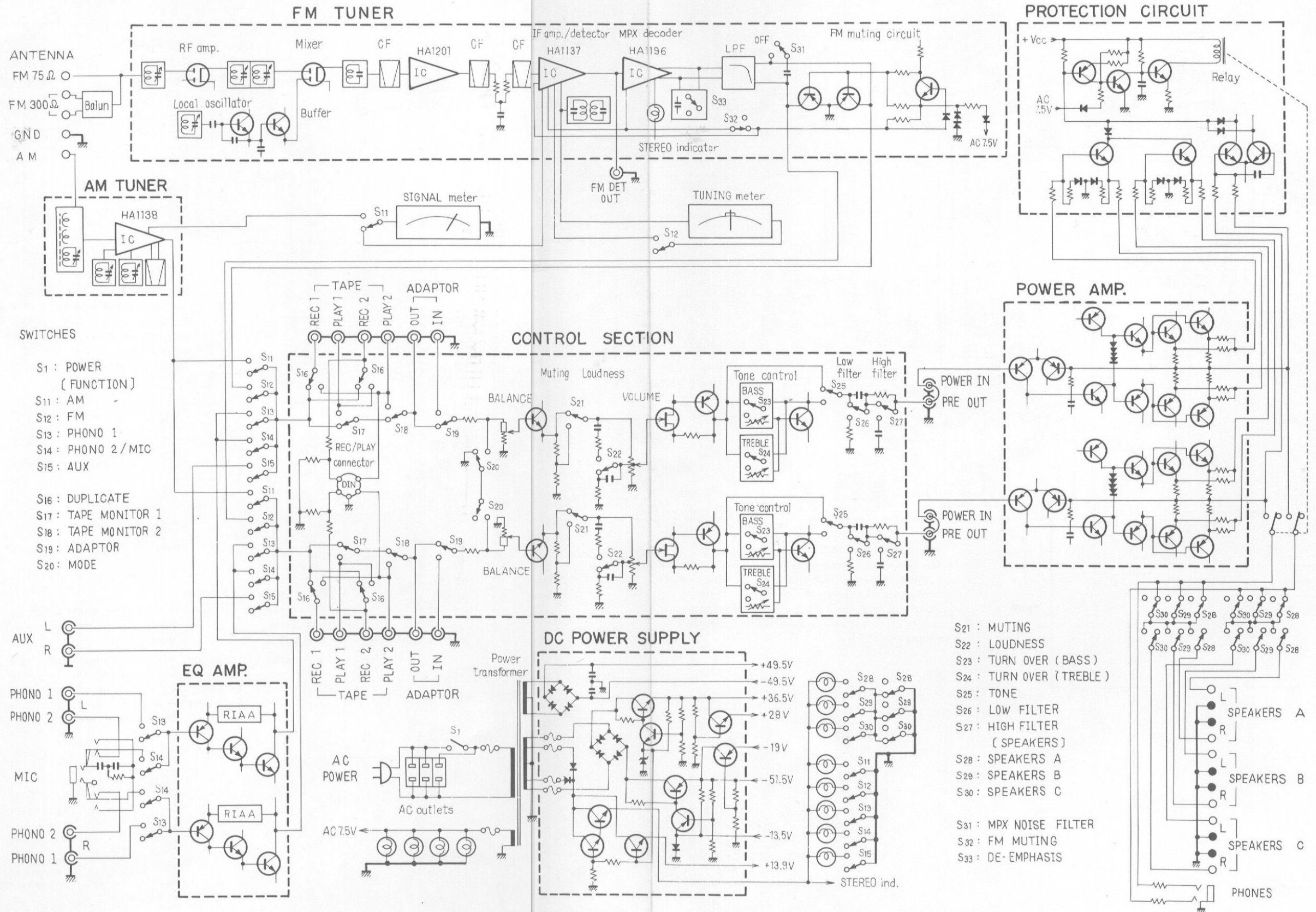

5. CIRCUIT DESCRIPTION

5.1 FM TUNER

Front End

This is composed of a tuning circuit with a 4-gang variable capacitor, dual-gate MOS FET RF amplifier, and local oscillator with buffer. By employing a grounded gate-2 of dual-gate MOS FET, the circuit becomes equivalent to a cascade amplifier, providing large gain with stable operation in the RF amplifier. At the mixer stage, the output from RF amplifier is applied to gate 1 and the local oscillator signal to gate 2. This method has advantages that no big power signal from the local oscillator is needed and there is the least mutual interference even when the input level is very high. The local oscillator is a variation of a Clapp circuit. Including the buffer amplifier between the mixer and oscillator reduces the load to local oscillator and eliminates waveform distortion. Since effects from the mixer stage are also not incurred, the drawing effect during strong inputs is eliminated and operation becomes extremely stable.

IF Amplifier and Detector Circuit

These are composed of 3 dual element ceramic filters and 2 integrated circuits (HA1201 and HA1137), HA1201 is a current-limiting limiter, such as shown in Fig. 1. Fig. 2 shows the HA1137 block diagram (see circuit diagram on page 51). HA1137 performs IF amplification, detection, meter drive and muting.

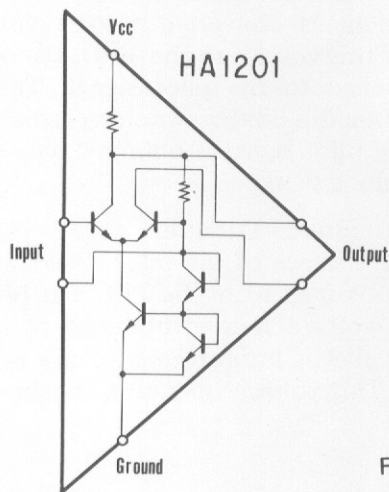

Fig. 1

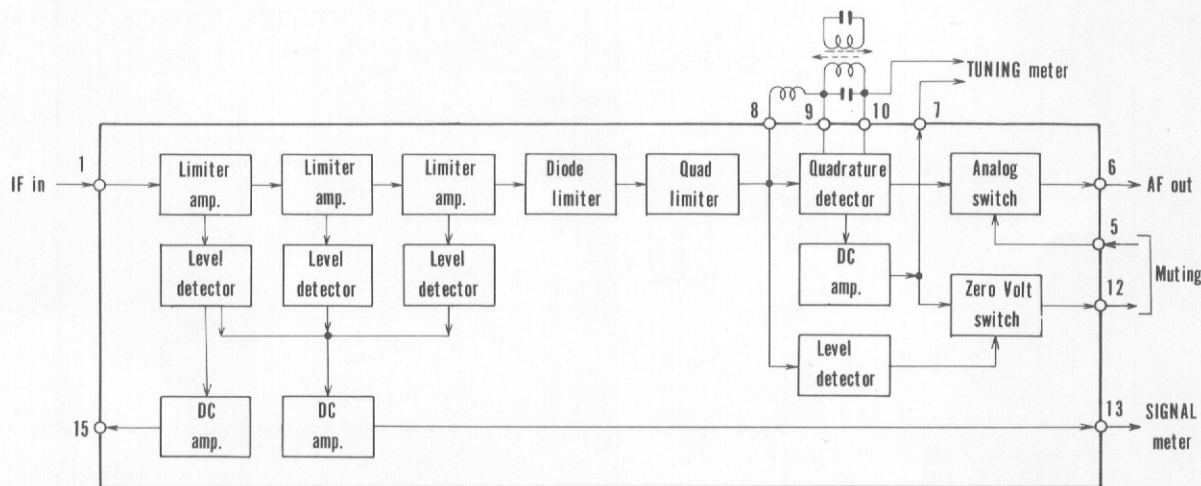

Fig. 2

Multiplex Decoder

This is comprised of three sections and employs an IC (HA1196) with a block diagram as shown in Fig. 3 (see page 51 for circuit).

1. Switching Signal Generator

A PLL (phase locked loop) system is employed. 76kHz is generated by the VCO (voltage controlled oscillator: an oscillator in which frequency is controlled by a voltage) and converted into 38kHz by a frequency divider, then divided again to become 19kHz. This signal and the stereo pilot component (19kHz) of the detected signal are applied to a phase comparator where the difference between them is converted into a voltage. By feedback of this voltage to the VCO, the oscillation signal is locked to the pilot signal. This loop is termed PLL and a 38kHz switching signal synchronized to the pilot signal is obtained and employed as the switching signal.

2. Automatic Stereo Detector

Presence or absence of the pilot signal is detected by 19kHz obtained from the PLL and phase comparator. A voltage is then obtained at the phase comparator that is proportional to the pilot signal amplitude. This voltage operate a trigger circuit. If

the pilot signal is present, the switching signal is applied to the demodulator and the Stereo indicator lights up. However, if the FM muting signal is also applied to pin 12, the detector circuit becomes grounded. Therefore switching signal to the demodulator is not supplied and mono reproduction is obtained.

3. Demodulator

This is a switching circuit employing two differential amplifiers (Fig. 4). The composite signal is applied to base of Q3. Q1 and Q2 are alternately switched ON and OFF by the switching signal. The composite signal amplified at Q3 is demodulated by switching of Q1 and Q2. Q6 and Q3 are loosely coupled at their emitters by R1—R3. Q6 is driven in opposite phase to Q3, the small composite signal is demodulated by switching of Q4 and Q5. The demodulated signals in opposite phase are composed with the collector of Q1 and Q2, crosstalk is cancelled.

Adequate current flow is required to Q3 and Q6 for improvement of distortion. However, if the base bias voltage is raised, the voltage utility at the collector becomes reduced and clipping occurs (power supply voltage is limited by IC voltage endurance). For this reason, current from an external source is inserted at Q3 and Q6 collectors to become I1 and I2. The same current amounts

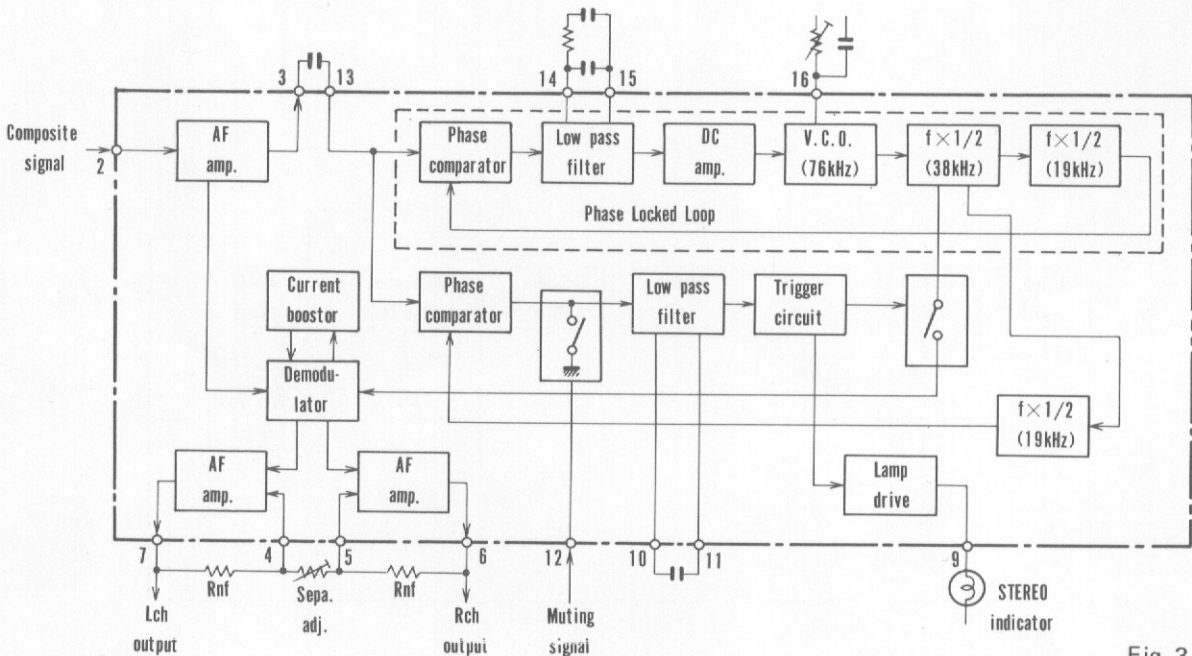

Fig. 3

are obtained as I3 and I4 from the emitters. Q3 and Q6 therefore operate with adequate current and distortion at this stage is remarkably improved. A feedback amplifier amplifies the demodulated signal to produce the IC output.

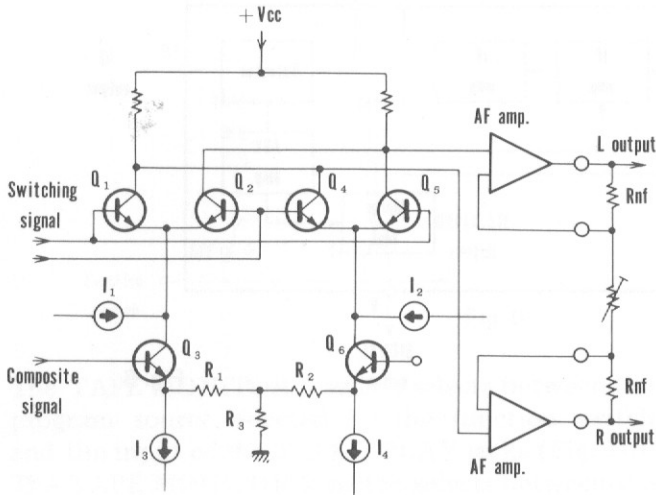

Fig. 4

FM Muting Circuit

Fig. 5 shows the FM muting circuit of the SX-950. When there is more than approximately $\pm 70\text{kHz}$ detuning or an extremely low input signal level, a DC voltage becomes generated at pin 12 of HA1137. This is taken as the detector signal for FM muting circuit operation.

In Fig. 5, the voltage of Q1 emitter is held to approximately -1.3V by D1 rectifying action and D2 and D3 forward voltage. When the received signal is extremely low (also includes detuning), a DC voltage (plus) is produced at pin 12 of HA1137 and with the FM MUTING switch ON, this voltage forward biases Q1 base through D4 and Q1 becomes ON. Q2 and Q3 base potentials are drawn by Q1 emitter potential and drop. Since Q2 and Q3 are PNP transistors, they are biased to forward and turn ON. The signal output circuit is thus grounded and muting is attained. At the same time, internal analogue switches in HA1137 is operated.

When the FM MUTING switch is OFF or a station is properly tuned, Q1 base is not forward biased. In this case, Q2 and Q3 base potentials are drawn by Q1 collector potential and rise. Q2 and Q3 therefore become OFF and muting is released.

Since the FM muting signal is also applied to the automatic stereo detector of HA1196 (multiplex decoder IC), muting and stereo thresholds are the same level.

When the power supply is switched ON, the negative voltage supply to Q1 emitter is more rapid than +Vcc increase. Q2 and Q3 thus become temporarily ON and muting is performed. On the other hand, when the power supply is turned OFF, the negative voltage at Q1 emitter is gradually declines. As +Vcc briefly maintained, Q2 and Q3 base potentials are drawn by the negative voltage at Q1 emitter, and they become ON again to perform muting.

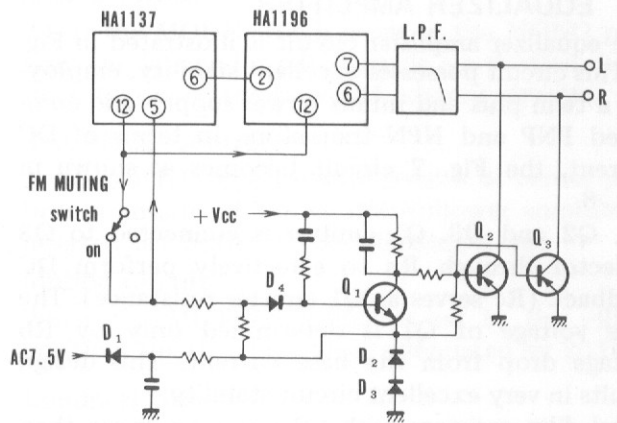

Fig. 5

5.2 AM TUNER

The AM tuner employs a 3-gang variable capacitor and an IC (HA1138) with 1 stage RF and 2 stage IF amplification. Fig. 6 shows the HA1138 block diagram (see page 51 for circuit).

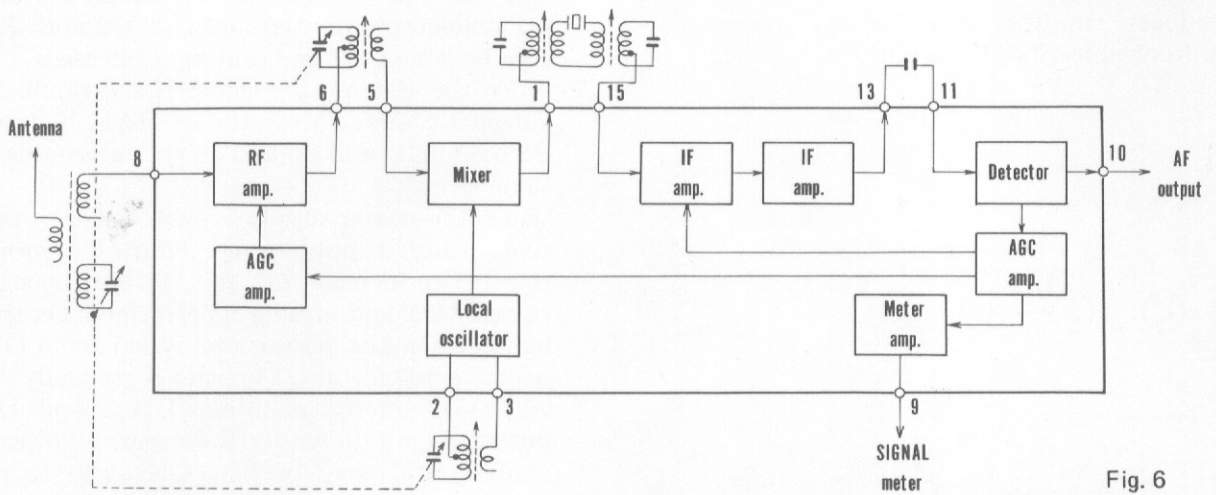

Fig. 6

5.3 EQUALIZER AMPLIFIER

The equalizer amplifier circuit is illustrated in Fig. 7. This circuit possesses excellent stability, employing a twin plus and minus power supply, and combined PNP and NPN transistors. In terms of DC current, the Fig. 7 circuit becomes as shown in Fig. 8.

Q1, Q2 and Q3. Q1 emitter is connected to Q3 collector through R_n to effectively perform DC feedback (R_c serves as Q1 emitter resistance). The base voltage of Q1 is determined only by R_b voltage drop from the base current. This design results in very excellent circuit stability.

Metal film resistors with tolerance no more than 1% and polystyrene film capacitors with tolerance no more than 2% are used in the equalizer elements. Deviation with respect to the RIAA playback standard is within $\pm 0.2\text{dB}$. As a result of the +28V and -19V power supplies, the overload input level at 0.1% distortion is 200mV (rms at 1kHz).

When a plug is inserted in the MIC jack and the function switch set to PHONO 2/MIC, the input signal from the MIC jack passes through a circuit which possesses corresponding response to the RIAA recording curve characteristic and is applied to the equalizer amplifier. The equalizer amplifier output response thus becomes flat with respect to an input from the MIC jack. Inserting a plug in the MIC jack breaks the PHONO 2 jack circuits.

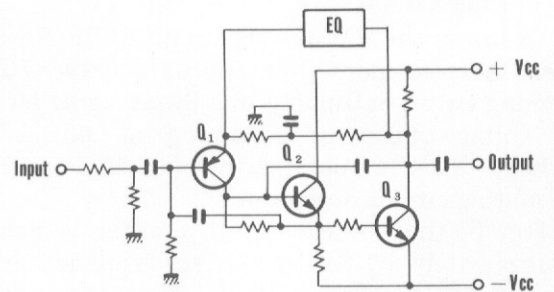

Fig. 7

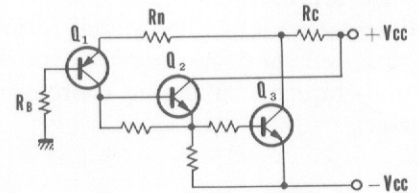

Fig. 8

5.4 CONTROL SECTION

Tape and Adaptor Circuits

With the DUPLICATE switch OFF, the program source selected by the function switch is obtained at the TAPE REC jacks (Fig. 9).

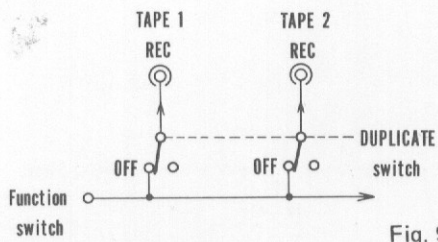

Fig. 9

The TAPE MONITOR 1 switch selects between the program source selected by the function switch and the input of the TAPE 1 PLAY jacks (Fig. 10). The TAPE MONITOR 2 switch selects between the signal selected by the TAPE MONITOR 1 switch and the input of the TAPE 2 PLAY jacks (Fig. 10).

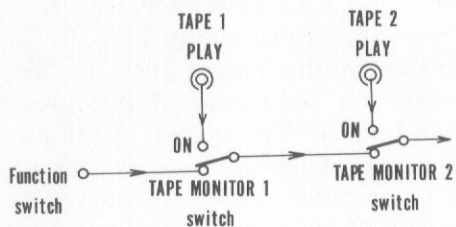

Fig. 10

When the DUPLICATE switch is set to ON, the TAPE 1 REC jacks become connected to the TAPE 2 PLAY jacks, and the TAPE 2 REC jacks to the TAPE 1 PLAY jacks (Fig. 11).

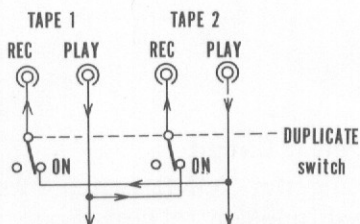

Fig. 11

The signal selected by the TAPE MONITOR 2 switch appears at the ADAPTOR OUT jacks (Fig. 12). The ADAPTOR switch selects between the signal selected by the TAPE MONITOR 2 switch and the input of the ADAPTOR IN jacks (Fig. 12).

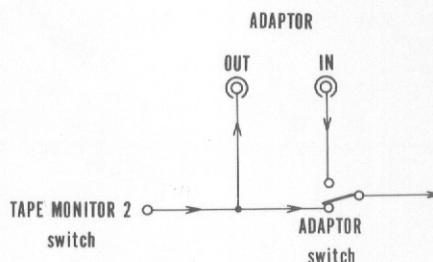

Fig. 12

MODE Switch

When the MODE switch is set to the MONO position, the left and right channels are shorted at the stage following the tape and adaptor circuits.

BALANCE Control

A no-loss HB type variable resistor at center position is employed. An emitter-follower amplifier is inserted as a buffer in the following stage.

Muting Circuit

When the MUTING switch is set to the -20dB position, the signal becomes attenuated by 20dB.

Loudness Circuit

This circuit is ON-OFF operated by the LOUDNESS switch and is intended to compensate for audibility characteristics of the human ear at low volumes. The VOLUME control variable resistor is tapped at the 40% point of its overall resistance. Connecting a CR network at this point enhances low and high frequencies at low volumes.

Tone Control Circuit

The SX-950 employs an NFB type tone control circuit. The signals are amplified to adequate level in the 2-stage direct coupled amplifier which is composed of an FET and transistor. The one transistor amplifier is inserted in the next stage and C-B feedback is applied. The selectivity of frequencies of C-B feedback provides tone adjustment. The basic circuit of this stage is shown in Fig. 13.

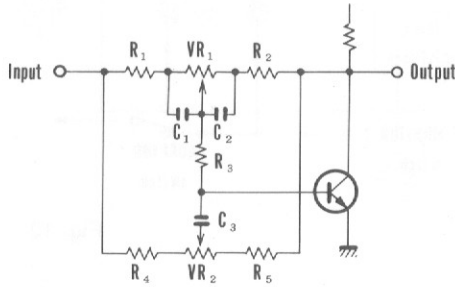

Fig. 13

to the degree the frequency declines and the NFB amount varies greatly according to VR1 slider position. The circuit gain at low frequencies can therefore be varied by VR1. Capacitance of C1 and C2 is changed by the BASS TURNOVER switch (by adding a capacitor to each in parallel). This allows selection of the frequency at which VR1 begins to take effect.

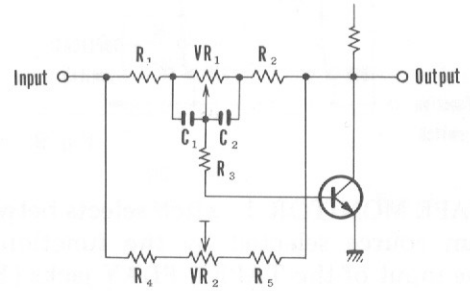

Fig. 15

Midrange Operation

C1 and C2 reactance is considerably smaller than VR1 at frequencies above midrange, effectively shorting VR1. At frequencies below midrange C3 reactance becomes large and in effect, open. Consequently, the circuit becomes as shown in Fig. 14 with respect to the midrange. In this figure, the circuit constant is not varied at any position of VR1 and VR2 sliders. The NFB amount is therefore fixed and the circuit gain is also fixed without regard to VR1 and VR2 slider positions.

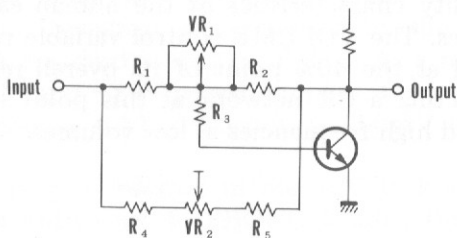

Fig. 14

High Frequency Operation

The considerably smaller reactance of C1 and C2 in comparison with VR1 effectively shorts VR1 to form a circuit such as shown in Fig. 16. C3 reactance decreases to the degree that the frequency increases and the NFB amount becomes largely varied according to VR2 slider position. Consequently, the gain at high frequencies can be varied by VR2. C3 capacitance is changed by the TREBLE TURNOVER switch (by adding another capacitor in series) to provide selection of the frequency at which VR2 begins to take effect.

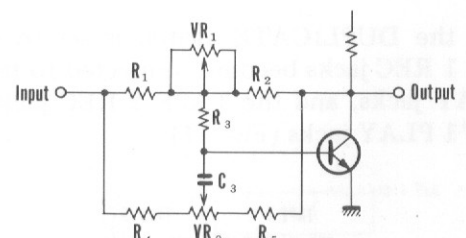

Fig. 16

Low Frequency Operation

The reactance of C1 and C2 increases to form a circuit as shown in Fig. 15. This reactance increases

Tone Defeat Circuit

By setting the TONE switch to OFF, the above described tone control circuit becomes bypassed.

Filter Circuits

Both low and high filters possess CR 1-stage -6dB/octave attenuation characteristics.

5.5 POWER AMPLIFIER

The SX-950 power amplifier employs all stage direct-coupled pure complementary circuit. It is an OCL circuit with balanced positive and negative power supply and center point DC potential kept at 0V (Fig. 17).

The first stage (Q1 and Q2) composes a differential amplifier designed for both signal amplification and stabilization of the center point potential. The predriver (Q3) is a class A amplifier. By providing a constant-current load (R7-R9, Q4, D2), the collector current can be designed for reducing noise figure (NF). A large gain can be obtained since the AC load can also be large.

The next stage (Q5 and Q6) composes a complementary circuit and employs a Darlington connection with the final stage. The final stage is a parallel SEPP circuit. D3 and VR2 provide bias after the driver stage.

Negative feedback is applied from the output stage center point to Q2 base. The AC NFB is determined by the dividing ratio between R10 and R11. Since C3 is open with respect to DC, 100% DC NFB is applied by R10-R12. Circuit DC gain becomes 0dB and the circuit is stable. However, as Q1 base potential variation becomes the center point potential variation, a bias stabilizing circuit (R1-R6, D1, VR1) is provided at Q1 base.

SPEAKERS Switches

The SX-950 is provided with 3 sets of speaker terminals (A, B, C). Since the power amplifier may become overloaded if all three sets are used simultaneously, when all 3 SPEAKERS switches are set to ON, the circuit functions as if all switches were OFF and the indicator lamps extinguish.

5.6 PROTECTION CIRCUIT

This circuit protects the power transistors in case of overload, the speakers in case of power amplifier malfunction, and also performs a muting function when the power supply is operated ON-OFF. The protection circuit is composed of three sections (Fig. 18).

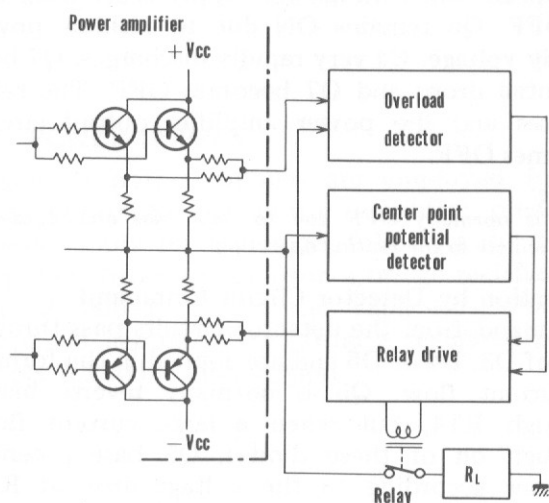

Fig. 18

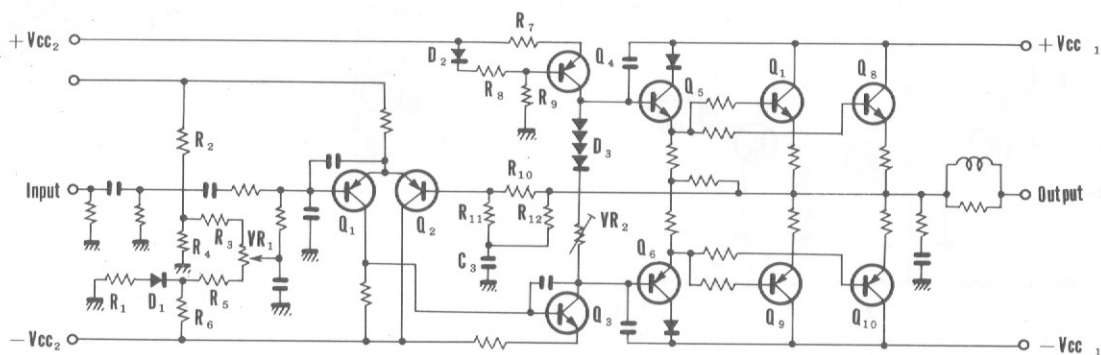

Fig. 17

1. Relay Drive Circuit (Fig. 19)

The relay which connects the output circuits is driven by this circuit. It also performs a muting function to prevent unpleasant noise during ON-OFF operation of the power supply and cuts the output circuit by command from the detector circuit.

Muting Operation

When the power supply is set from OFF to ON, Q6 base is reverse biased through D6 and R19—R21, turning Q6 OFF. Q7 base potential rises with C4 charging through R22 & R23, Q7 becomes ON several seconds later. The collector current of Q7 then flows through the relay coil, operating the relay to turn on the power amplifier output circuit. The reverse bias of Q6 base from D6 & R19—R21 disappears when the power supply is set from ON to OFF. Q6 remains ON due to residual power supply voltage. C4 very rapidly discharges, Q7 base potential drops and Q7 becomes OFF. The relay releases and the power amplifier output circuit becomes OFF.

Note:

Q5 is normally OFF due to base bias and does not participate in the muting operation.

Operation by Detector Circuit Command

Command from the detector circuits pass through one of D3, D4 or D5 and are applied in the form of a current flow. Q5 is normally reverse biased through R14, but when a large current flows through one of these diodes, Q5 base potential declines according to the voltage drop at R14. Q5 then becomes ON, Q6 base potential rises and Q6 becomes ON. C4 rapidly discharges and Q7 base potential drops, turning Q7 OFF. The relay releases and the power amplifier output circuit becomes cut off.

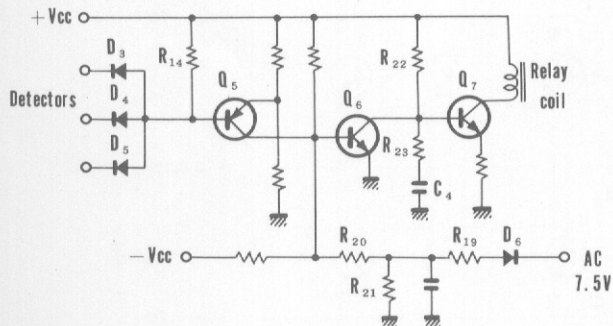

Fig. 19

2. Overload Detector Circuit

Shorting of the power amplifier load or a load impedance below the specified value causes a command to be sent to the relay drive circuit. This operating principle is shown in Fig. 20.

With the output stage in class B operation, when Qa is operating in the positive half cycle, Qb becomes cut off and the signal current flows as indicated by the solid arrows in Fig. 20. Point D potential at this time is the point A potential divided by R1 and R3. Also, point C potential is the point A potential divided by RE1 and RL (load). Point D is connected to Q1 base and point C to Q1 emitter through R2 and RE2. When RL is extremely small, the point C potential becomes considerably lower than point D. This potential difference forward biases Q1. Q1 becomes ON and current flows in D3.

Qb operates in the negative half cycle and Qa becomes cut off. The signal flows as indicated by the broken line arrows in the center of Fig. 20. Q1 is biased by the potential difference between point C and point E. If RL is extremely small, the point C potential becomes considerably higher than that of point E. Q1 becomes ON and current flows in D3.

If large current flows in Qa and Qb, Q1 becomes ON by RE1 and RE2 voltage drop, and current flows in D3. C1 prevents faulty operation due to external noise.

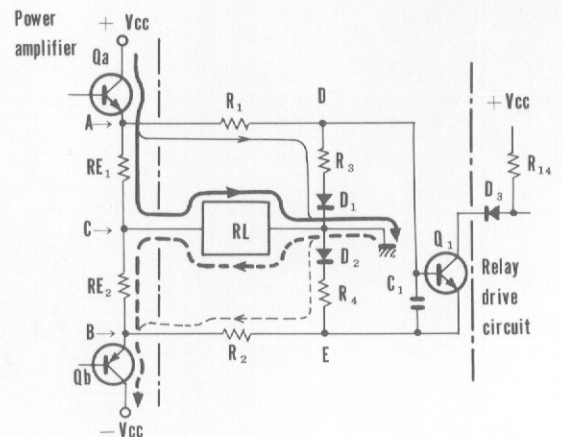

Fig. 20

3. Center Point Potential Detector Circuit

If DC potential is produced at the junction point of the power amplifier, the command is sent to the relay drive circuit. Fig. 21 shows this operating principle.

Q3 and Q4 compose a differential amplifier. When the same input is applied to both input terminals (Q3 and Q4 bases), output is absent. However, if there is a difference between the terminal inputs, the difference is amplified and becomes the output between the two collectors. During normal operation, an AC signal only is present at the junction point. As C2 reactance is sufficiently low, the same signal is applied to Q3 and Q4 bases, resulting in an absence of output at the collector sides.

When a DC potential is produced at the junction point, it becomes the input of Q3 only. If the voltage is negative, Q3 collector current declines. And at Q4 the collector current increases and the potential drops, causing current to flow through D4.

If the DC voltage is positive, Q3 collector current increases and the potential drops, while at Q4 the collector current decreases and potential rises. Current therefore flows through D5.

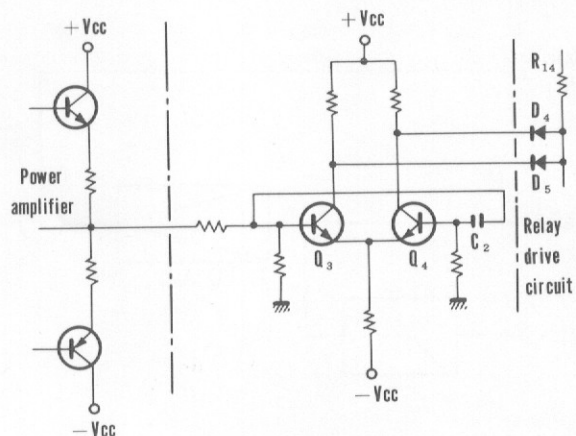
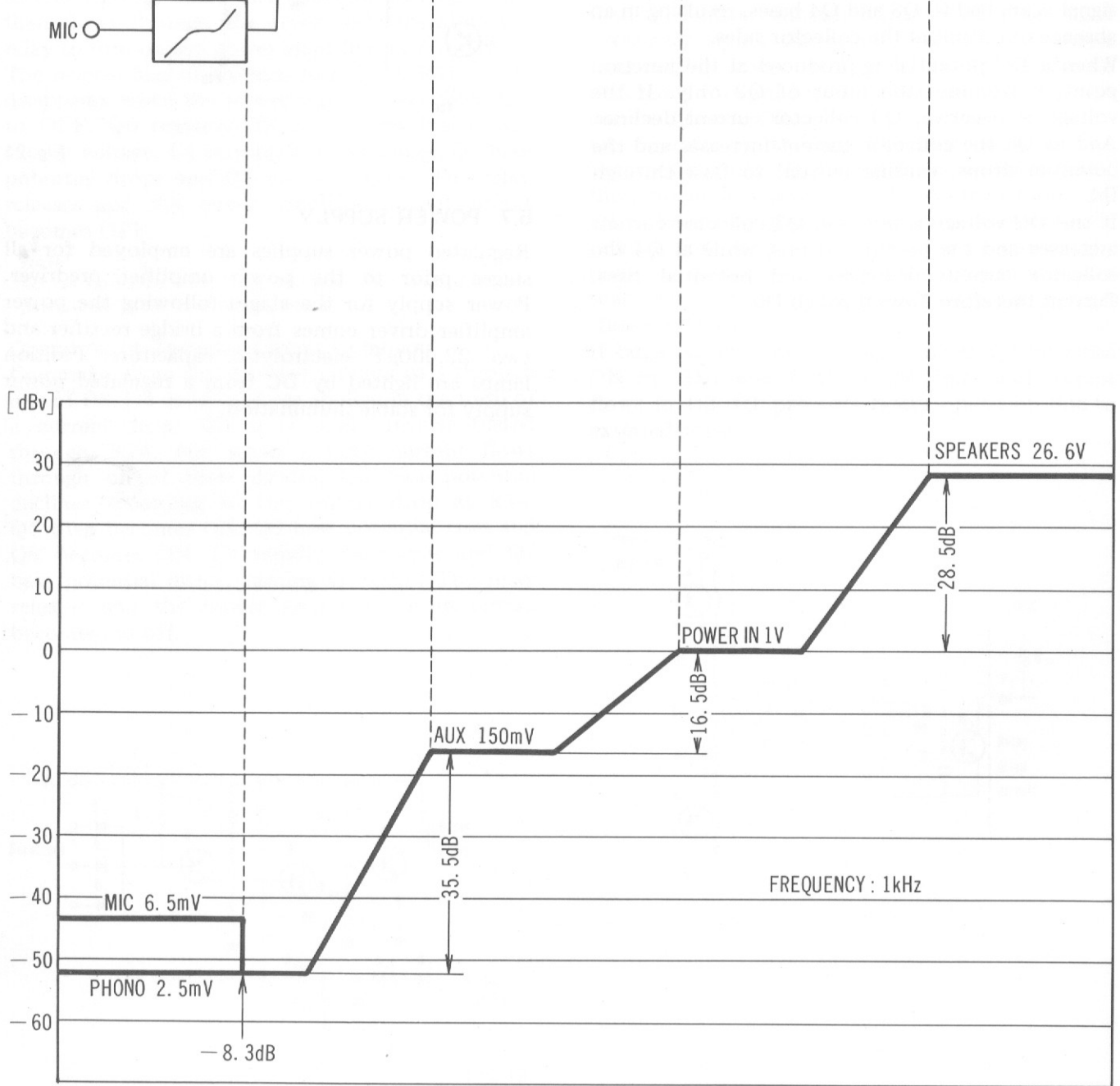
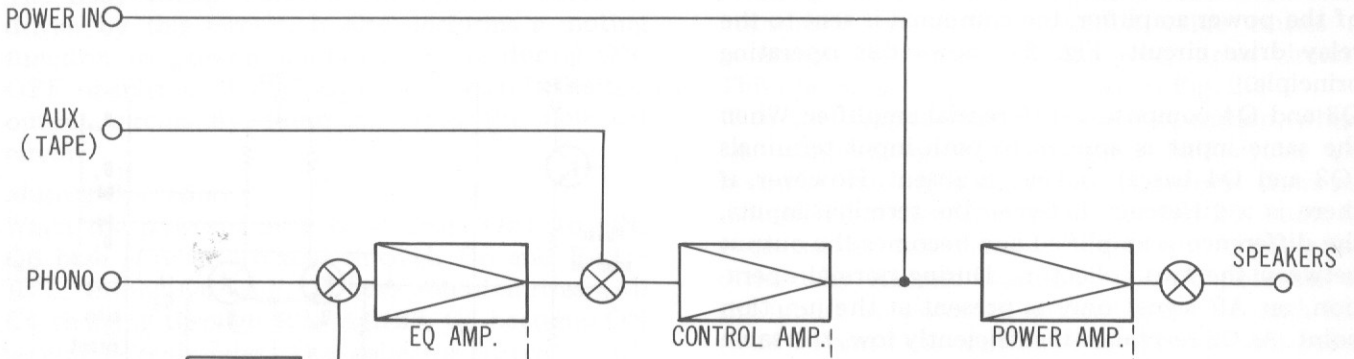

Fig. 21

5.7 POWER SUPPLY

Regulated power supplies are employed for all stages prior to the power amplifier predriver. Power supply for the stages following the power amplifier driver comes from a bridge rectifier and two 22,000 μ F electrolytic capacitors. Position lamps are lighted by DC from a regulated power supply for stable illumination.

6. LEVEL DIAGRAM



7. DISASSEMBLY

Wooden Cover

Remove the two screws on each side of the wooden cover.

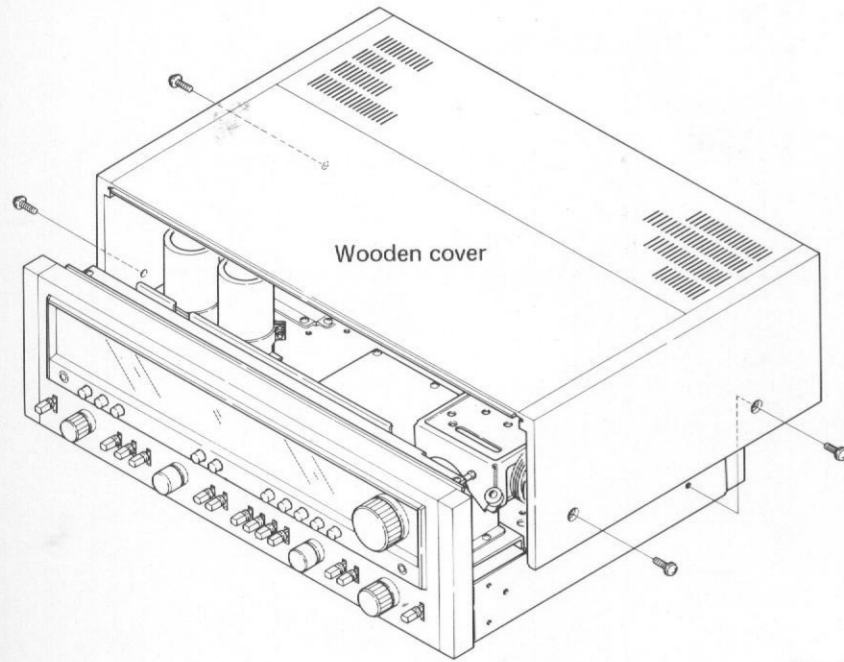

Fig. 22

Bottom Plate

Remove the eleven screws to detach the bottom plate.

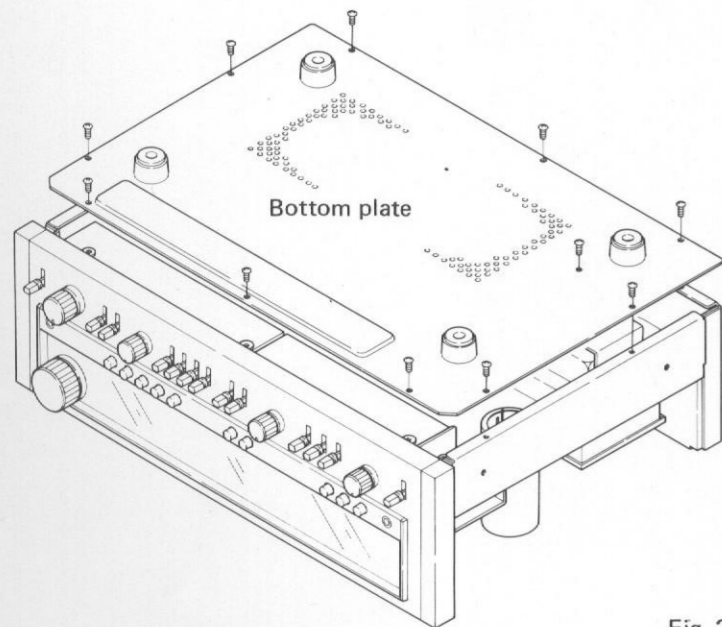

Fig. 23

Front Panel

Loosen the setscrew of TUNING knob with a hexagonal wrench. Remove all the knobs by pulling. Remove the two screws from the top edge of the front panel. Remove the three nuts from the tone and volume control shafts.

Tone Amplifier Assembly

Remove the three screws (A).

Flat Amplifier Assembly

Remove the three screws (B).

Switch Assembly (SPEAKERS)

Remove the four screws (C).

Switch Assembly (FM MUTING, MPX NOISE FIL)

Remove the two screws (D).

Switch Assembly (AM, FM, PHONO 1, PHONO 2/MIC, AUX)

Remove the two screws (E).

Microphone Jack Assembly

Remove the two screws (F).

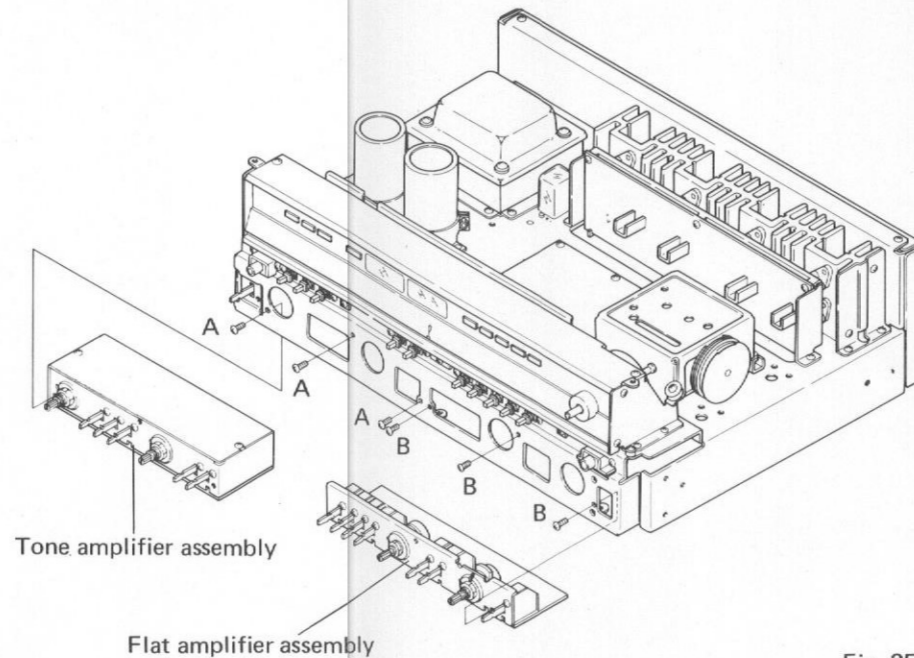

Tone amplifier assembly

Flat amplifier assembly

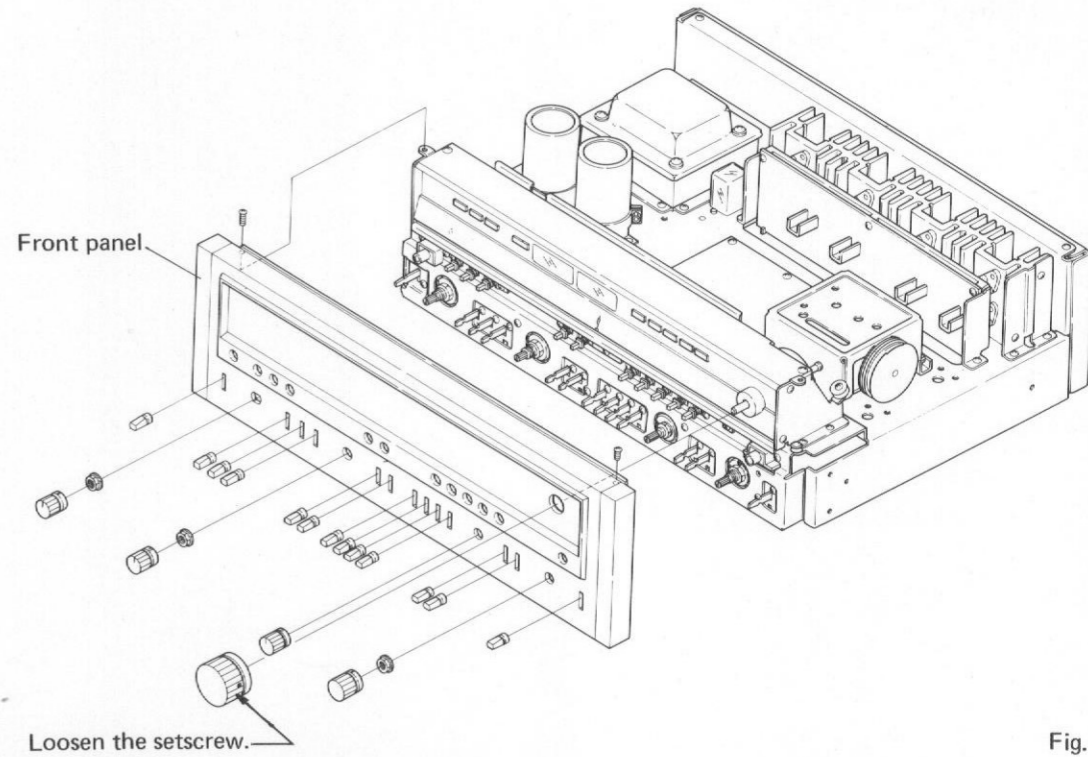

Front panel

Loosen the setscrew.

Fig. 24

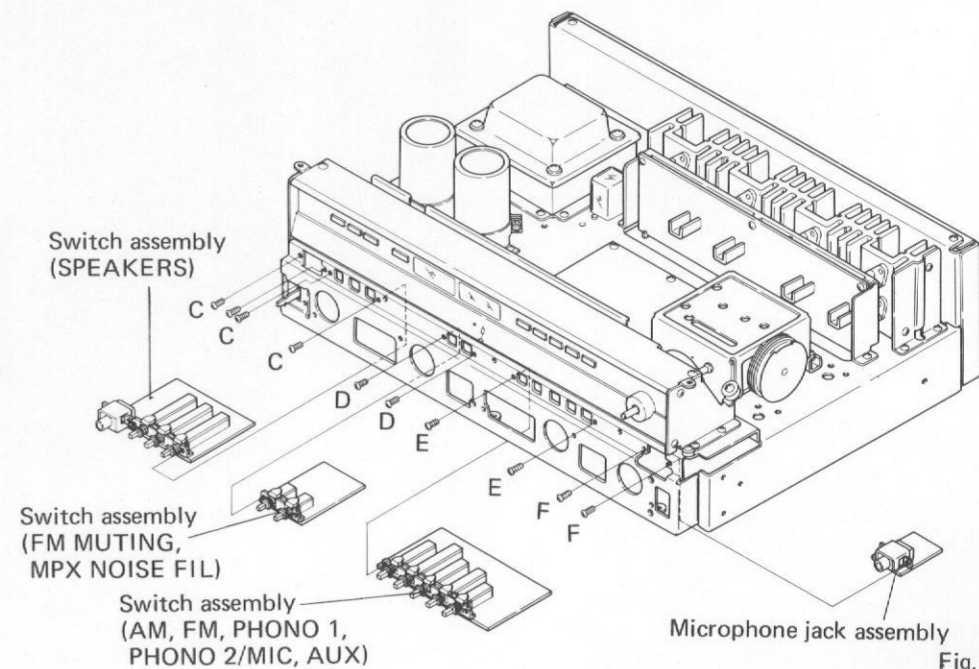

Switch assembly (SPEAKERS)

Switch assembly (FM MUTING, MPX NOISE FIL)

Switch assembly (AM, FM, PHONO 1, PHONO 2/MIC, AUX)

Microphone jack assembly

Fig. 25

Fig. 26

8. PARTS LOCATIONS

8.1 FRONT PANEL VIEW

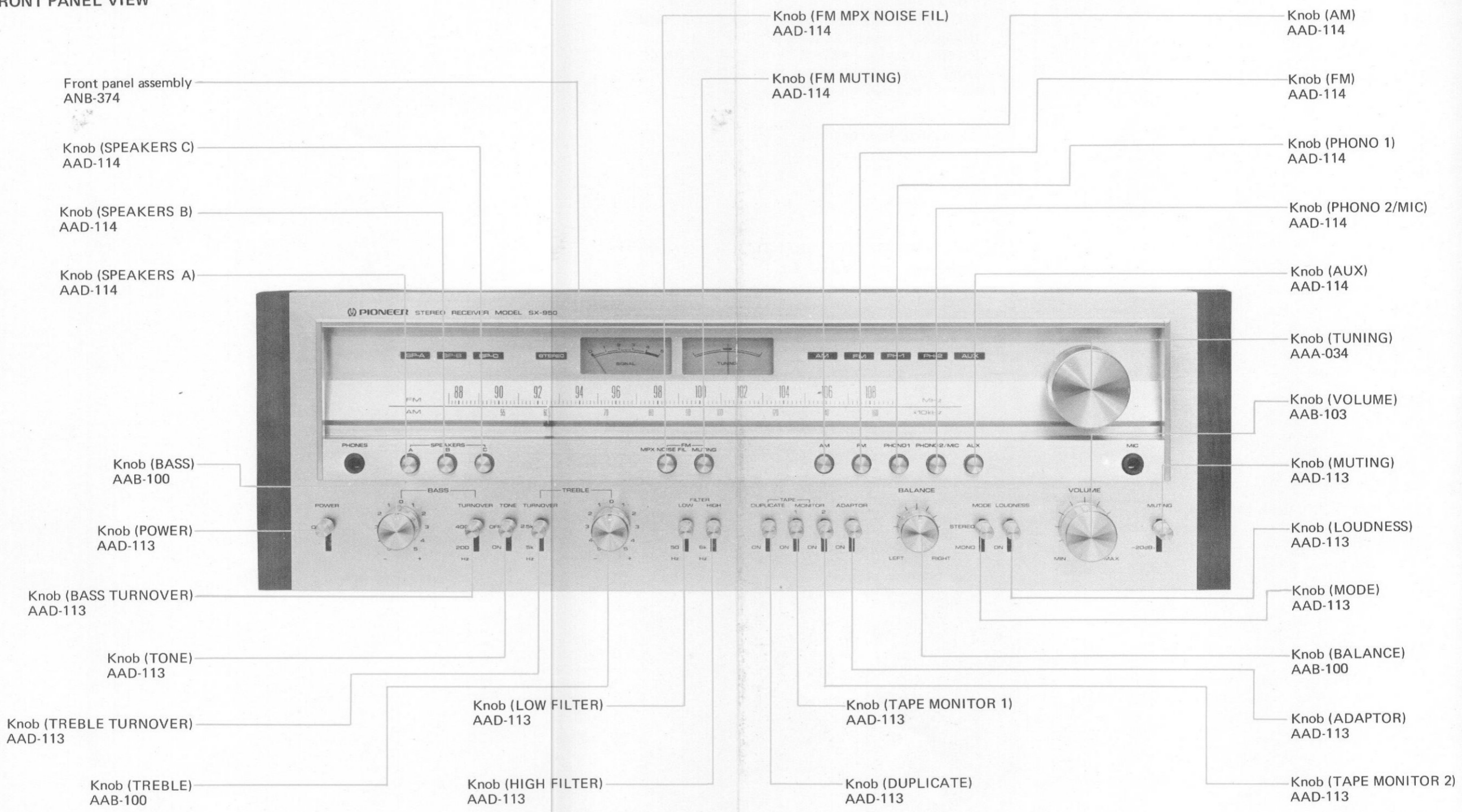

8.2 FRONT VIEW WITH PANEL REMOVED

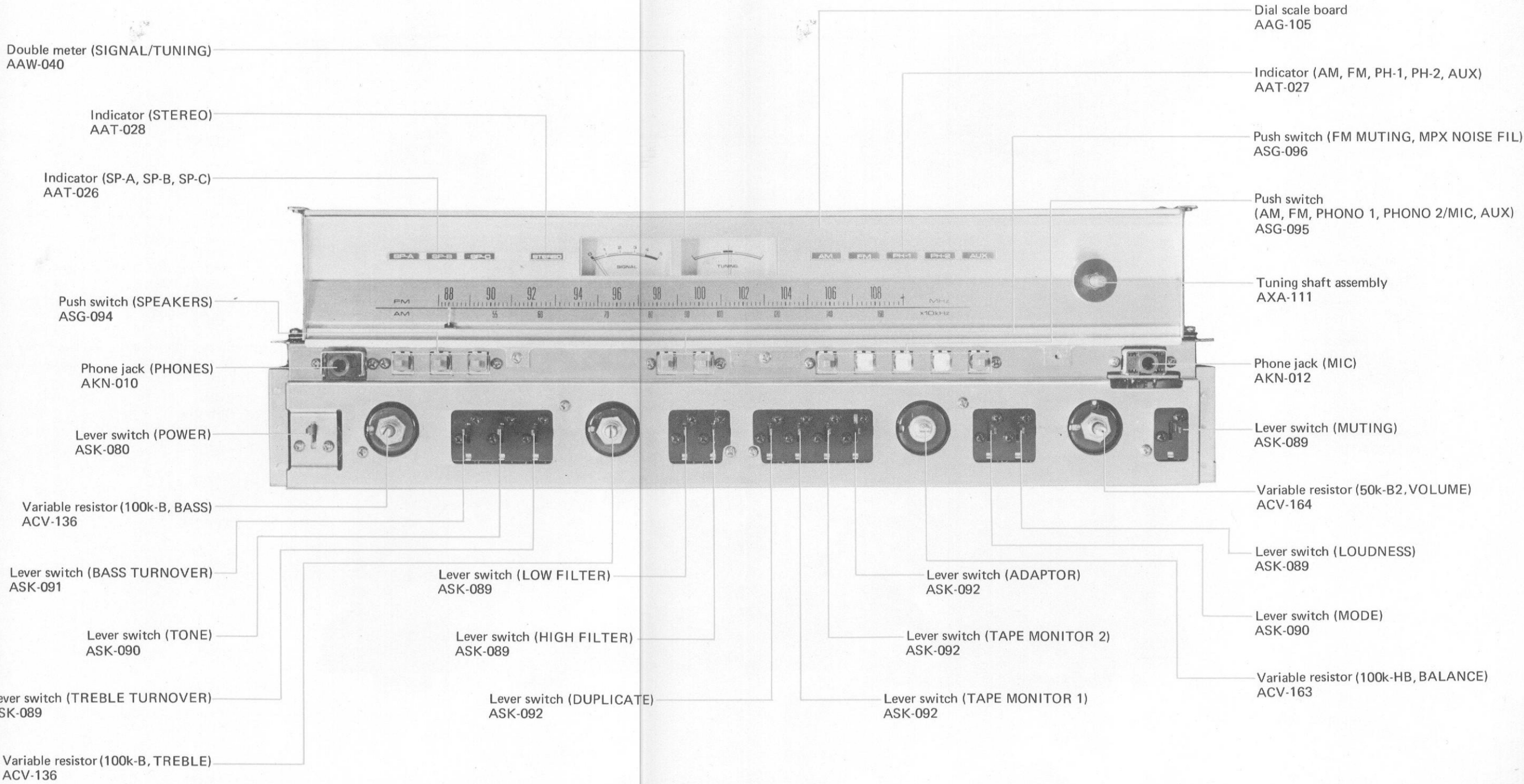

8.3 TOP VIEW

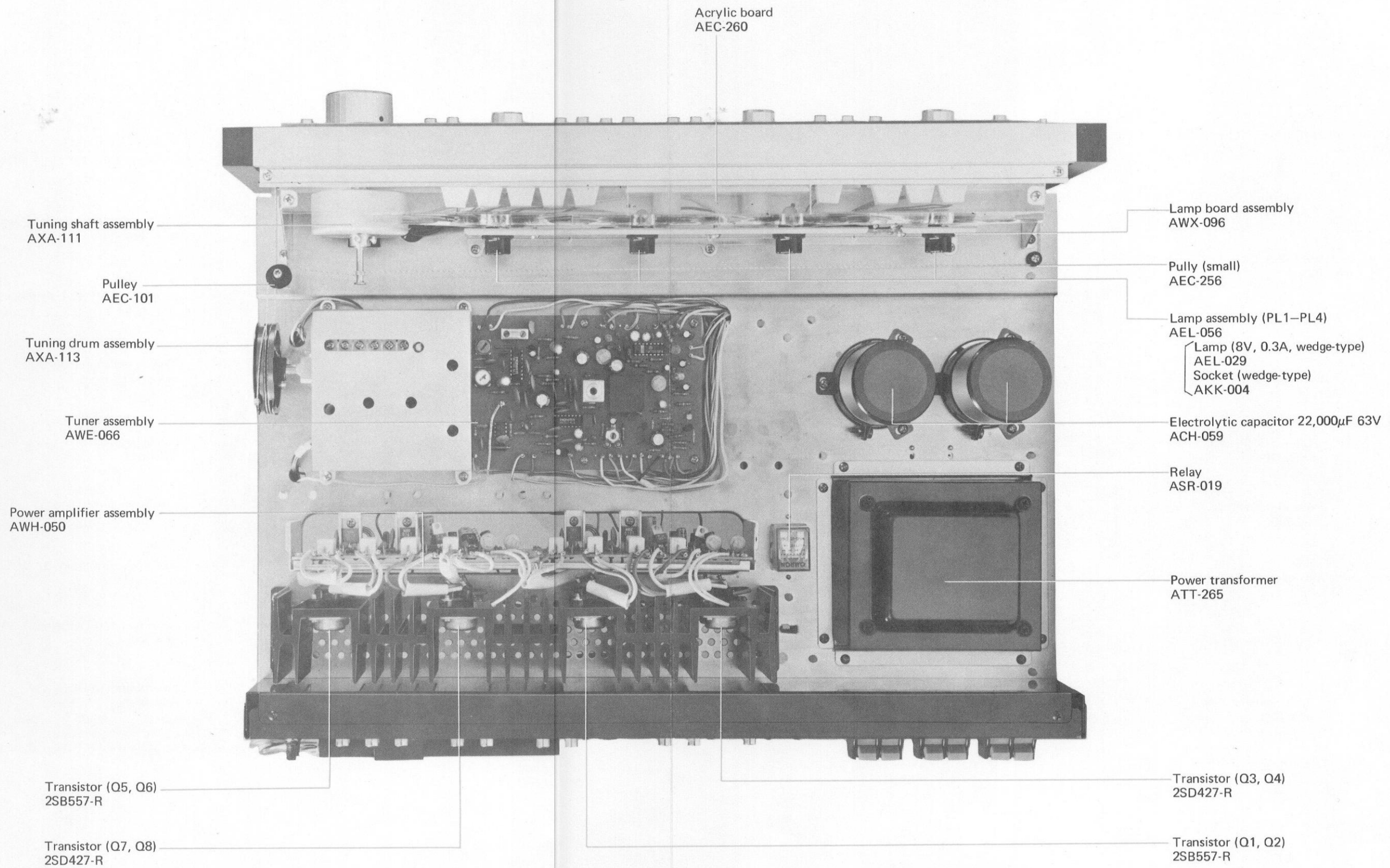

8.4 BOTTOM VIEW

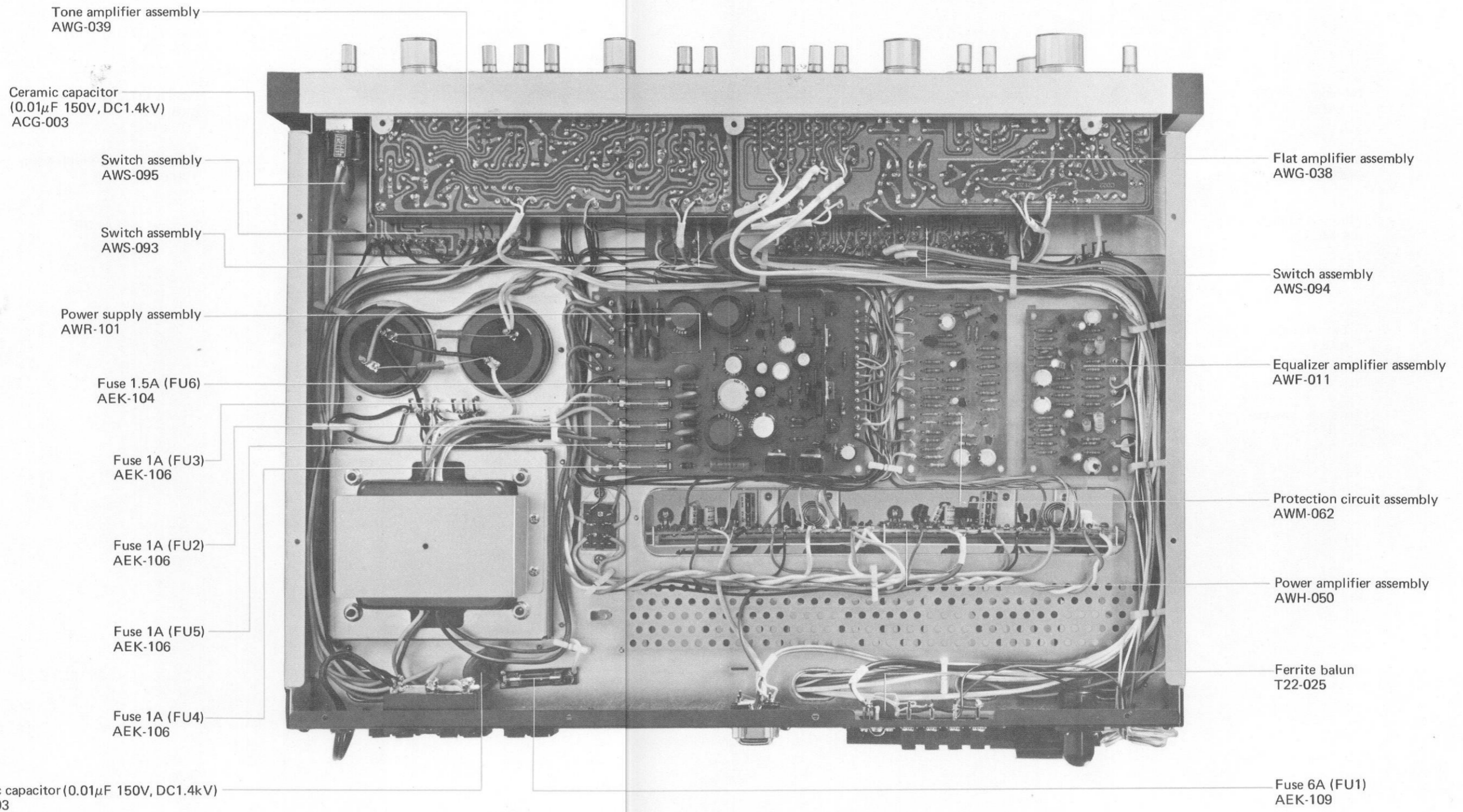

8.5 REAR VIEW

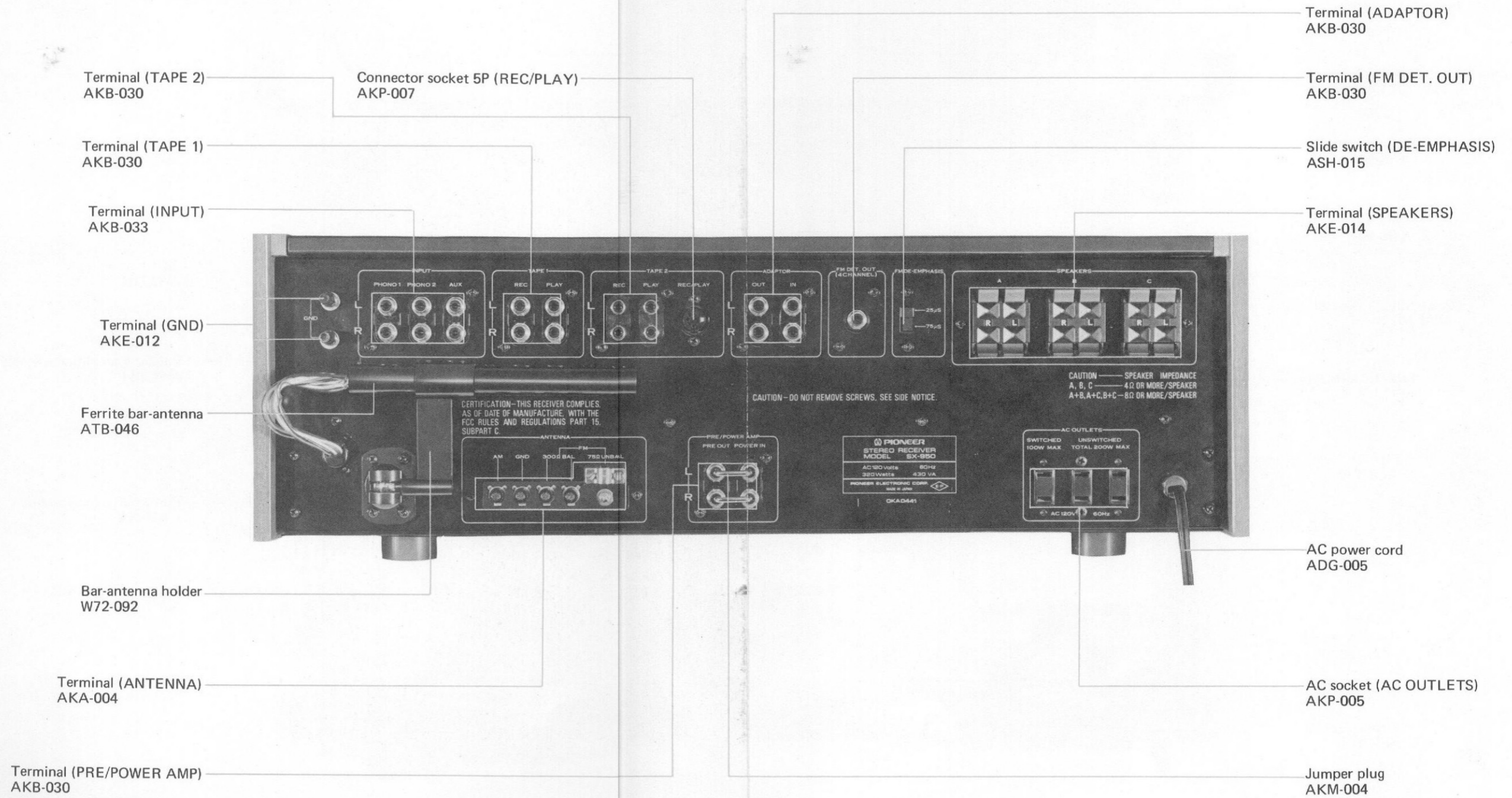

9. ADJUSTMENTS

9.1 AM TUNER

1. Set function switch to AM.
2. Connect AM signal generator through 1k-ohm resistor to AM antenna terminal.
3. Set DUPLICATE switch to OFF and connect an AC voltmeter to TAPE 1 REC jacks.
4. Set AM SG for 400Hz 30% modulation 100dB output.
5. Set SX-950 dial indication and AM SG frequency for 600kHz.
6. Adjust T8 core for maximum reading on AC voltmeter.
7. Set SX-950 dial indication and AM SG frequency for 1,400kHz.

8. Adjust TC5 for maximum reading on AC voltmeter.
9. Set AM SG for 30dB output.
10. Set SX-950 dial indication and AM SG frequency for 600kHz.
11. Adjust T7, T8 and bar antenna core for maximum reading on AC voltmeter.
12. Set SX-950 dial indication and AM SG frequency for 1,400kHz.
13. Adjust TC5, TC6 and TC7 for maximum reading on AC voltmeter.
14. Repeat steps 10~13 to eliminate variations in AC voltmeter readings.

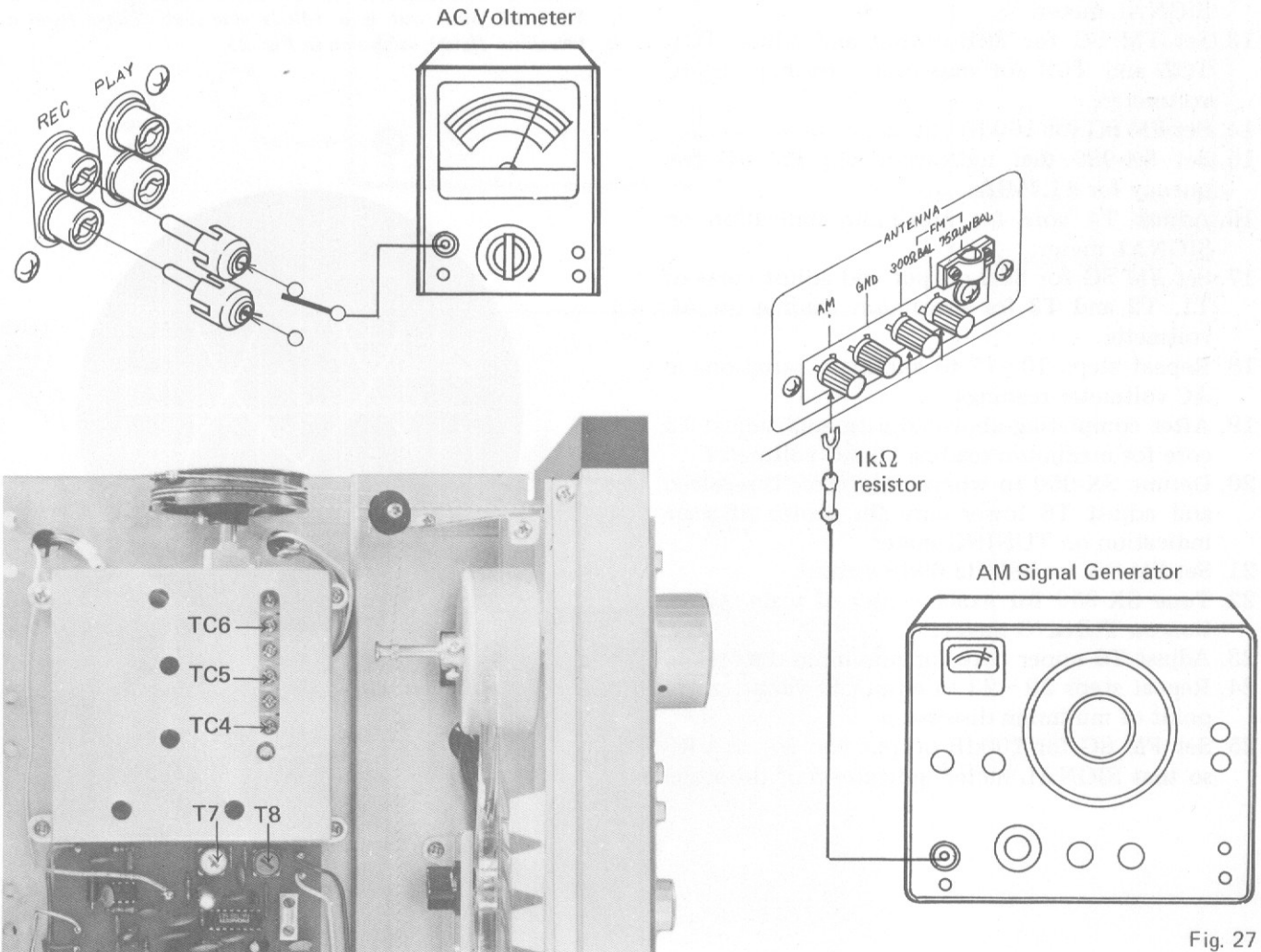

Fig. 27

9.2 FM TUNER

1. Set function switch to FM.
2. Set FM MUTING switch to OFF.
3. Connect FM signal generator through 300-ohm dummy load to 300 ohm FM antenna terminals.
4. Set DUPLICATE switch to OFF and connect AC voltmeter to TAPE 1 REC jacks.
5. Set FM SG for 100dB output at 400Hz and 100% modulation.
6. Set SX-950 dial indication and FM SG frequency for 87.4MHz.
7. Adjust T4 core for maximum indication on SIGNAL meter.
8. Adjust T6 lower core for center of scale indication on TUNING meter.
9. Set FM SG for 8dB output and adjust cores of T1, T2, and T3 for maximum reading on AC voltmeter.
10. Set FM SG for 100dB output.
11. Set SX-950 dial indication and FM SG frequency for 106MHz.
12. Adjust TC4 for maximum indication on SIGNAL meter.
13. Set FM SG for 8dB output and adjust TC1, TC2 and TC3 for maximum reading on AC voltmeter.
14. Set FM SG for 100dB output.
15. Set SX-950 dial indication and FM SG frequency for 87.4MHz.
16. Adjust T4 core for maximum indication on SIGNAL meter.
17. Set FM SG for 8dB output and adjust cores of T1, T2 and T3 for maximum reading on AC voltmeter.
18. Repeat steps 10~17 to eliminate variations in AC voltmeter readings.
19. After completing above adjustments, adjust T5 core for maximum reading on AC voltmeter.
20. Detune SX-950 to where only noise is received and adjust T6 lower core for center of scale indication on TUNING meter.
21. Set FM SG for 98MHz 60dB output.
22. Tune SX-950 for exact center of scale indication on TUNING meter.
23. Adjust T6 upper core for minimum distortion.
24. Repeat steps 20~23 to eliminate variations in point of minimum distortion.
25. Set FM SG for 100dB output and adjust VR3 so that SIGNAL meter indicates 5 of the scale.

Multiplex Decoder

26. Connect MPX SG (multiplex signal generator) to the external modulator terminals of the FM SG and set the FM SG for external modulation.
27. Connect PILOT OUT terminal of MPX SG to horizontal input terminal of oscilloscope.
28. Through probe, connect oscilloscope vertical input terminal to terminal No. 19.
29. Set FM SG for 98MHz 60dB output unmodulated.
30. Tune SX-950 for exact center of scale indication on TUNING meter.
31. Adjust VR1 so that 4 : 1 frequency ratio Lissajous' (see note below) figure becomes stationary.
32. Set FM SG for 1kHz (L or R), ± 67.5 kHz deviation, 19kHz (pilot signal) and ± 7.5 kHz modulation.
33. Adjust VR2 for minimum L-R crosstalk.

Note:

Signal at terminal No. 19 is 76kHz sawtooth wave and MPX SG pilot out is a 19kHz sinewave. These form a Lissajous' figure as shown in Fig. 28.

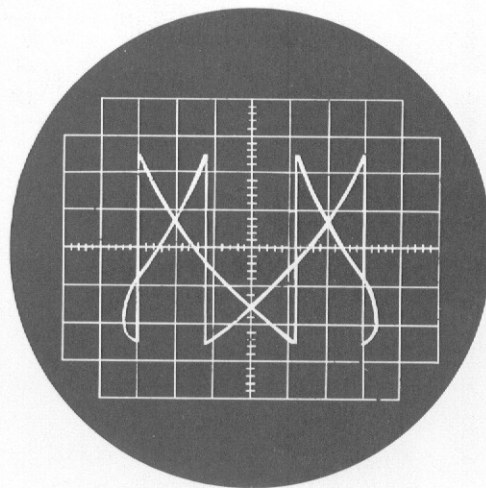

Fig. 28

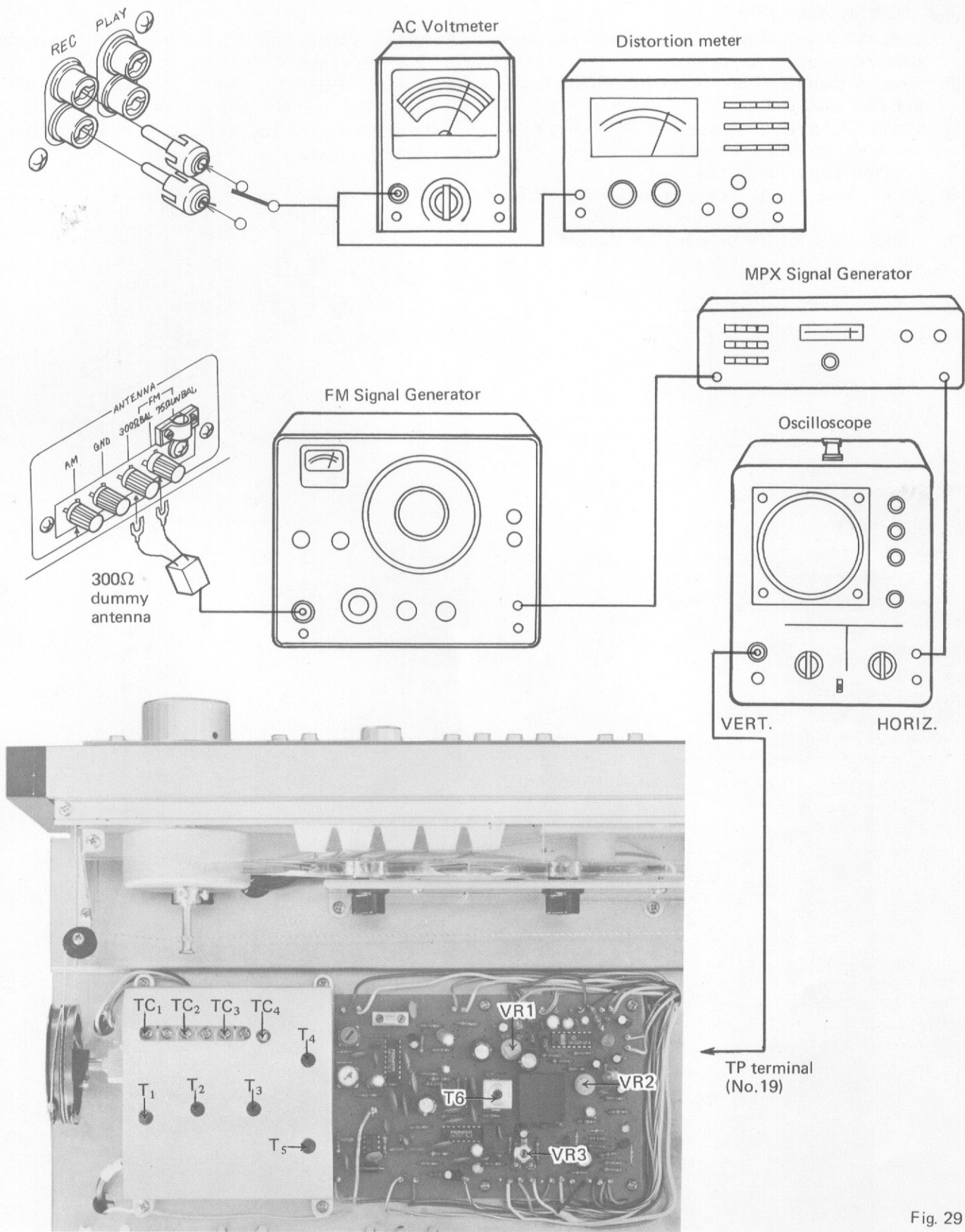

Fig. 29

9.3 POWER AMPLIFIER

1. Turn VR3 and VR4 fully counter-clockwise before turning on the power.
2. Remove jumper plugs connecting POWER IN and PRE OUT jacks.
3. Connect 5.1 k-ohm resistor to POWER IN jacks.
4. Set power amplifier for no load.
5. Set POWER switch to ON.
6. Adjust VR1 for 0V between terminals No. 10 and No. 9.
7. Adjust VR2 for 0V between terminals No. 25 and No. 24.
8. Adjust VR3 for 20mV between terminals No. 12(+) and No. 13(-).
9. Adjust VR4 for 20mV between terminals No. 27(+) and No. 28(-).
10. Allow set to warm up for at least 10 minutes, then readjust.

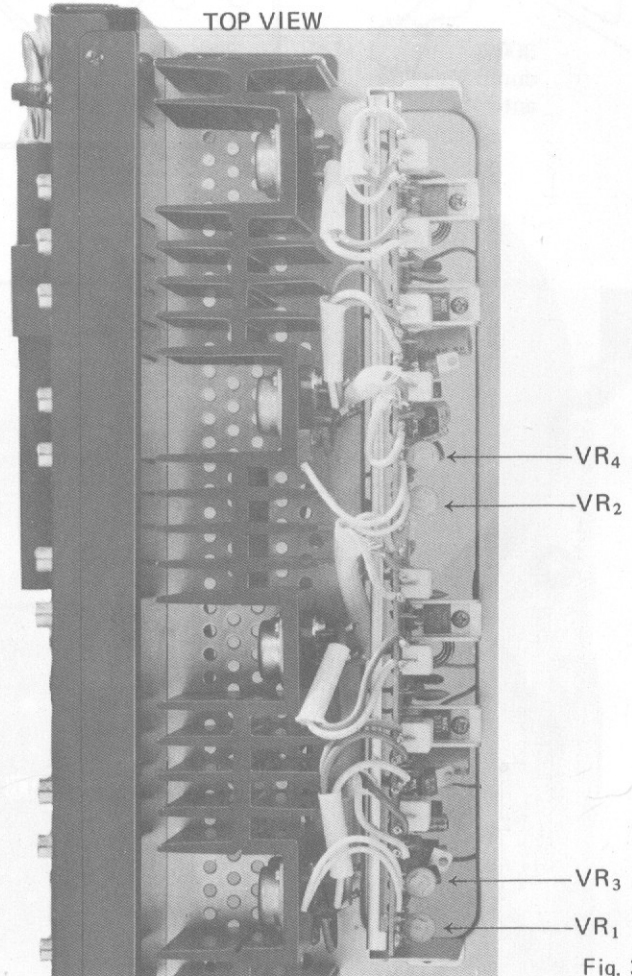
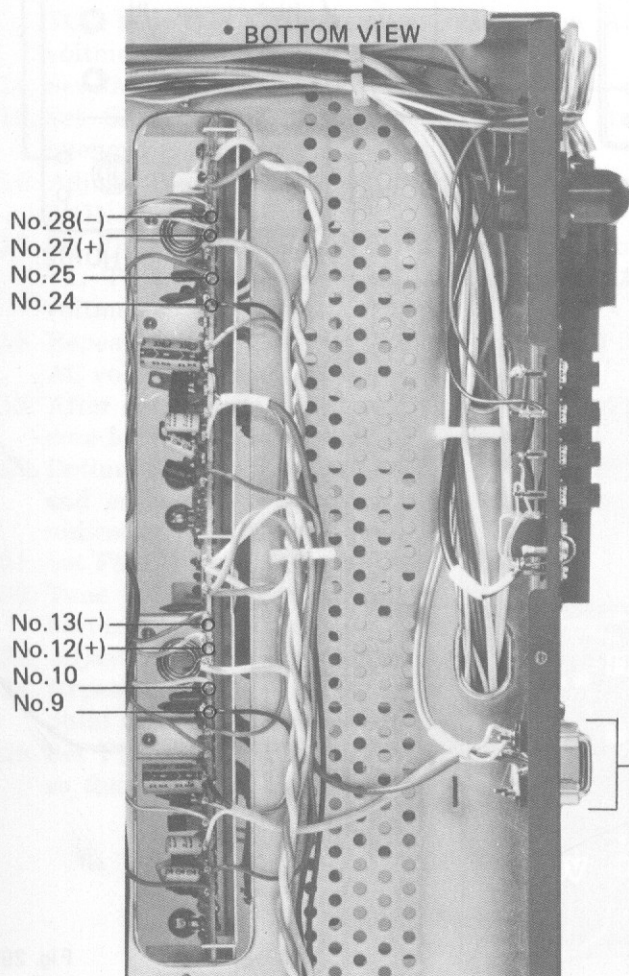
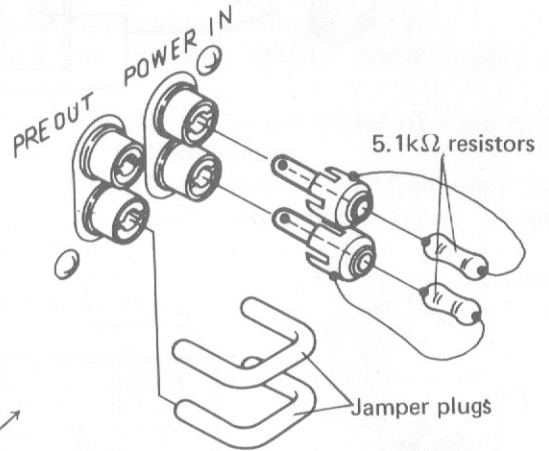
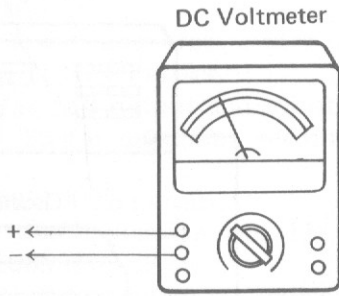

Fig. 30

10. DIAL CORD STRINGING

1. Remove the wooden cover and the front panel.
2. Remove the three screws to detach the blind sash (Fig. 31).
3. Turn tuning drum fully clockwise (as viewed from X direction in Fig. 32).
4. Tie one end of cord to stud on inner section of tuning drum (more easily performed by loosening setscrew and temporarily removing tuning drum from shaft).
5. Route cord through tuning drum cutout, make a half turn around the drum, then route in sequence to pulley A—dial pointer—pulley B—pulley C.
6. Wind cord 3 turns clockwise (as viewed from rear panel) around tuning shaft, then route to pulley D.
7. Wind cord two turns around tuning drum and tie to spring hook so that tension is applied to the cord.
8. Turn TUNING knob and confirm normal cord motion, then trim off excess cord.
9. With tuning drum at step 1 setting, restrain cord from moving and slip dial pointer on cord. Align it with the starting point (extreme left end of frequency scale).

Dial Pointer Installation Caution

Metal portion of dial pointer is plated approximately 0.2μ . If this section is touched directly by hand or fingerprints and other impurities, contamination is difficult to remove from aventurine finish. As this is not desirable in terms of both appearance and anticorrosion, use extreme care not to touch the metal section when handling the dial pointer.

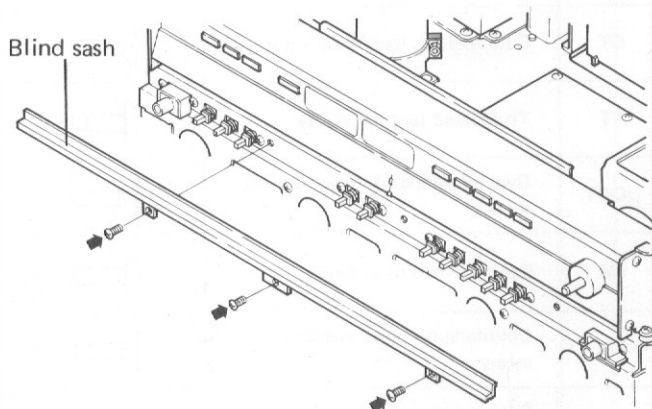

Fig. 31

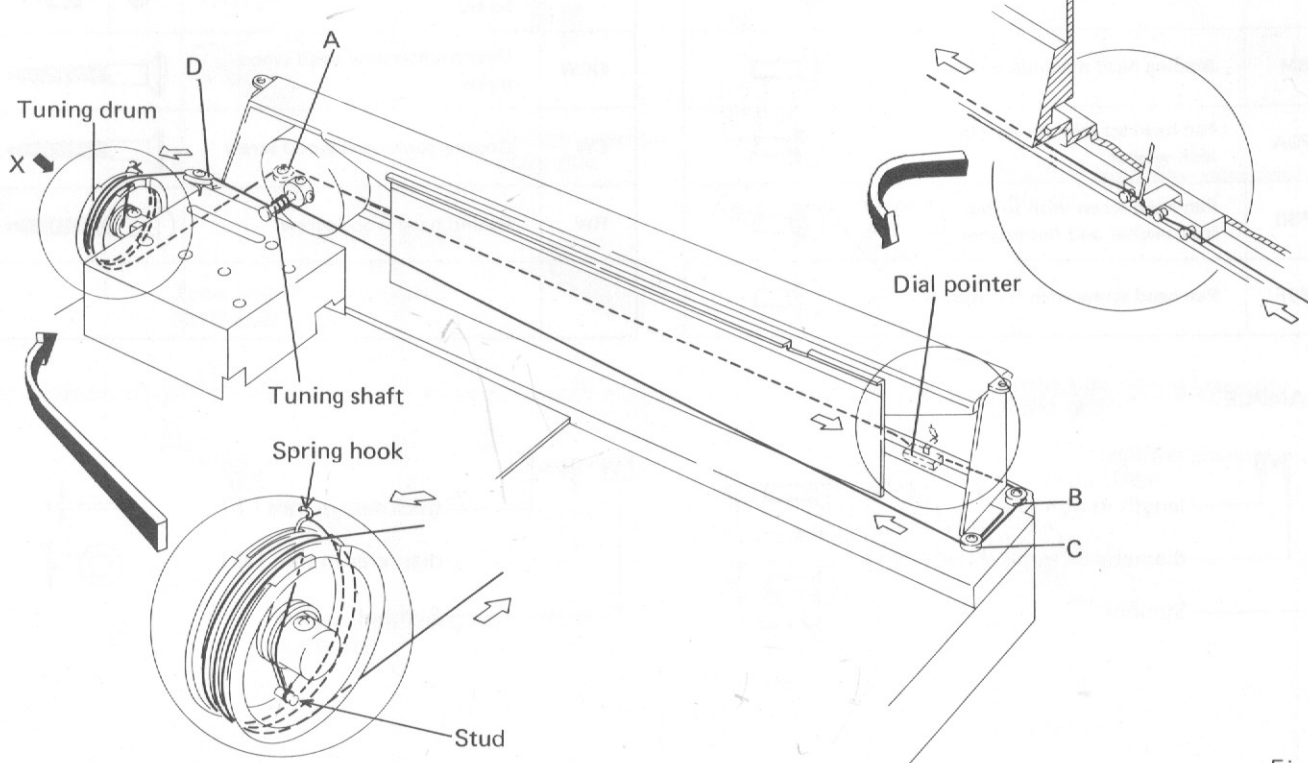



















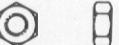
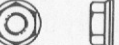
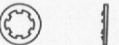







Fig. 32

11. EXPLODED VIEWS

NOMENCLATURE OF SCREWS, WASHERS AND NUTS

The following symbols stand for screws, washers and nuts as shown in exploded view.

Symbol	Description	Shape
T	Brazier head tapping screw	
PT	Pan head tapping screw	
BT	Binding head tapping screw	
CT	Countersunk head tapping screw	
TT	Truss head tapping screw	
OCT	Oval countersunk head tapping screw	
PM	Pan head machine screw	
CM	Countersunk head machine screw	
OCM	Oval countersunk head machine screw	
TM	Truss head machine screw	
BM	Binding head machine screw	
PSA	Pan head screw with spring lock washer	
PSB	Pan head screw with spring lock washer and flat washer	
PSF	Pan head screw with flat washer	

Symbol	Description	Shape
EW	E type washer	
FW	Flat washer	
SW	Spring lock washer	
N	Nut	
WN	Washer faced nut	
ITW	Internal toothed lock washer	
OTW	Outernal toothed lock washer	
SC	Slotted set screw (Cone point)	
SF	Slotted set screw (Flat point)	
HS	Hexagon socket headless set screw	
OCW	Oval countersunk head wood screw	
CW	Countersunk head wood screw	
RW	Round head wood screw	

EXAMPLE

PM · 3x8
 length in mm (l)
 diameter in mm (d)
 Symbol

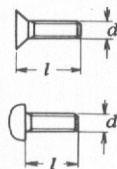

FW · 9 ϕ x 1^t
 thickness in mm (t)
 diameter in mm (d)
 Symbol

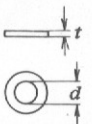

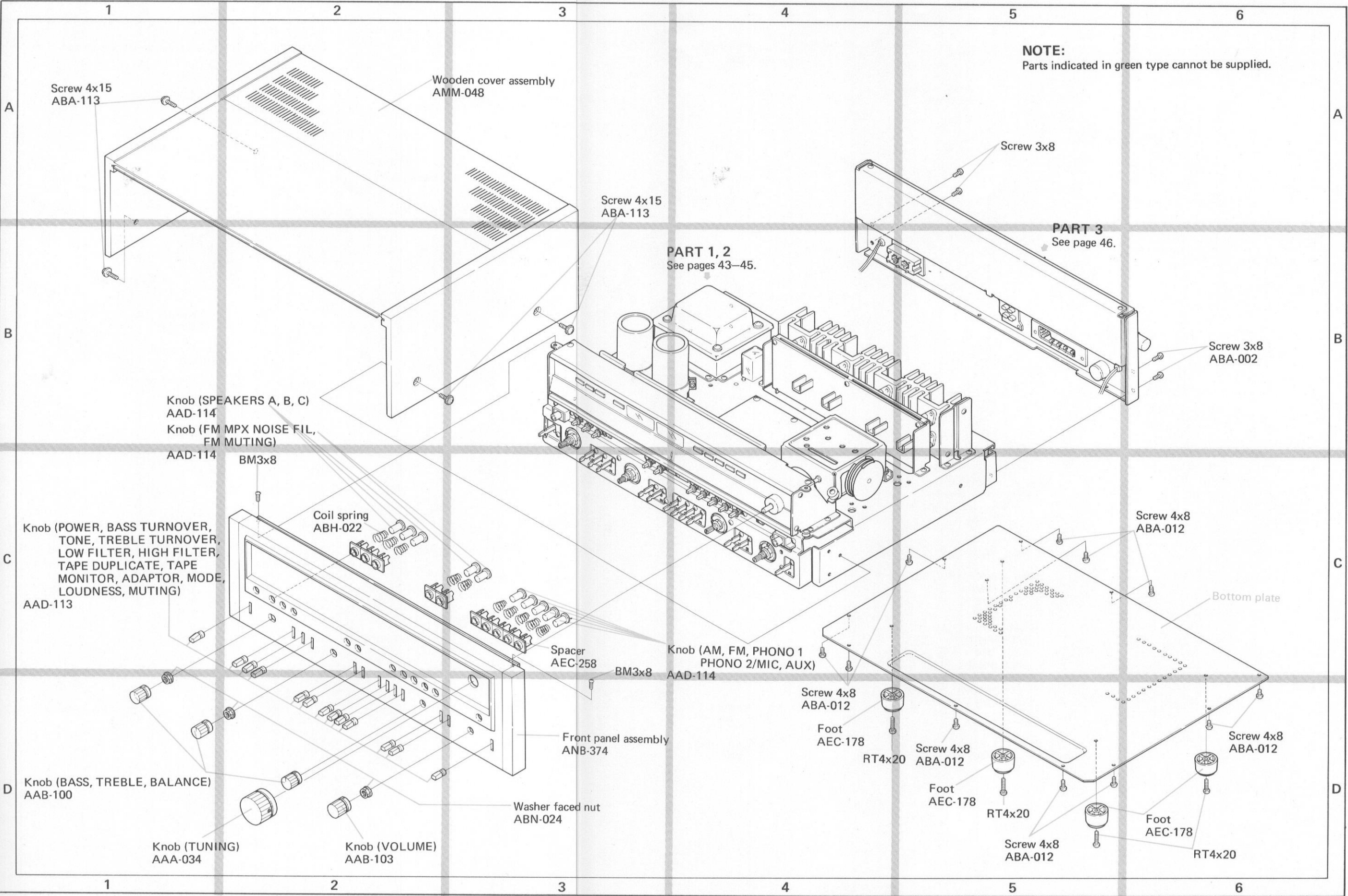

NOTE:
Parts indicated in green type cannot be supplied.

1

2

3

Part 2

NOTE:

Parts indicated in green type cannot be supplied.

A

A

B

B

C

C

D

D

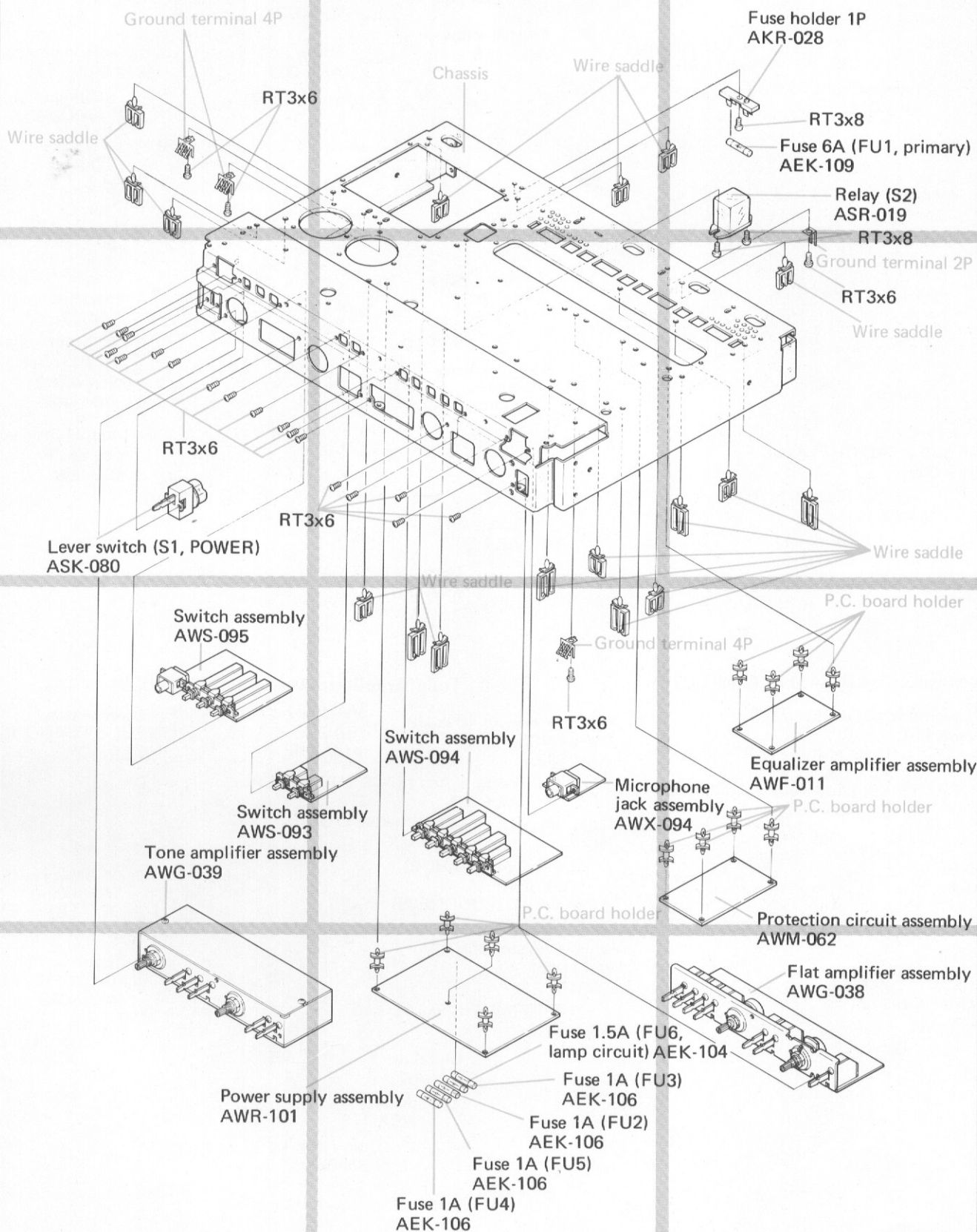

1

2

3

Part 3

NOTE:

Parts indicated in green type cannot be supplied.

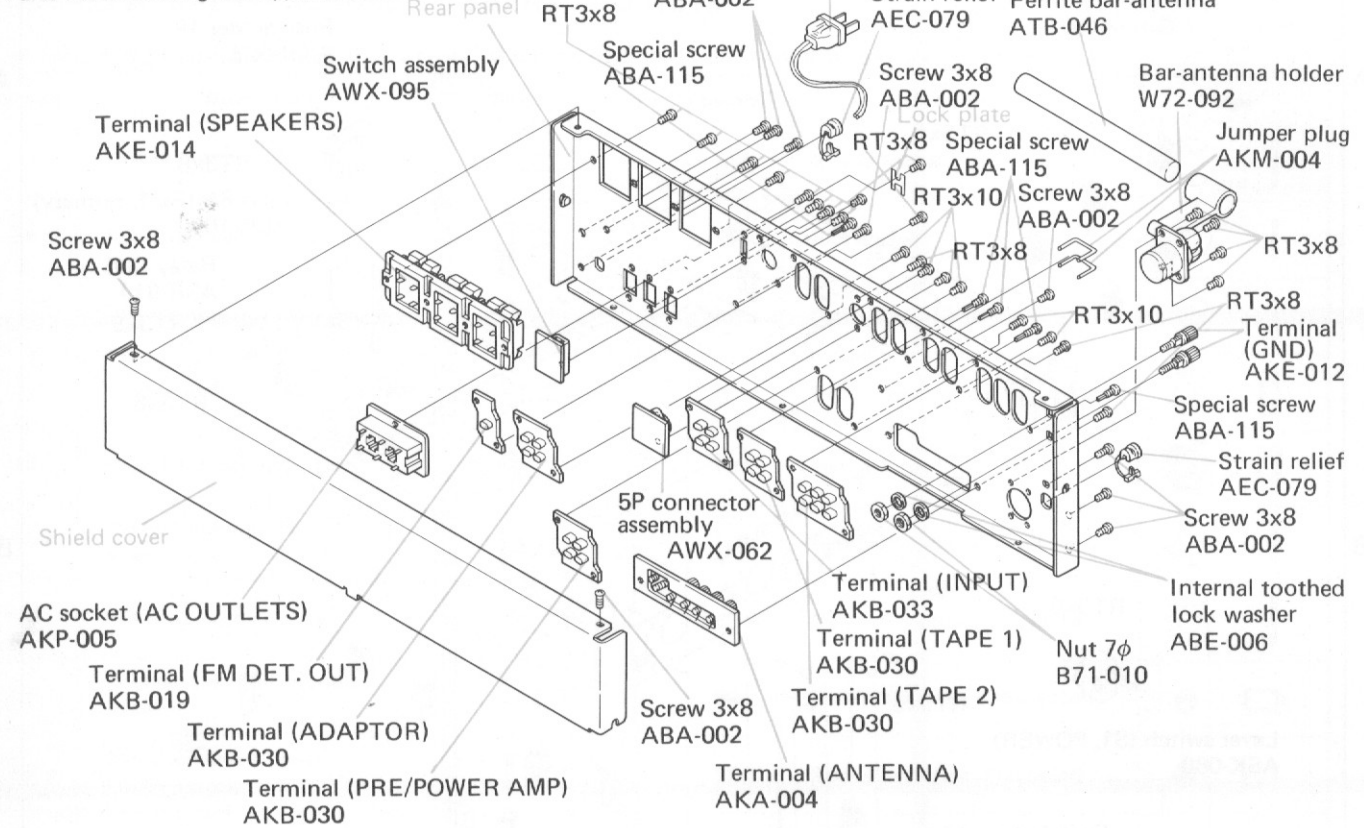

Flat Amplifier Assembly (AWG-038)

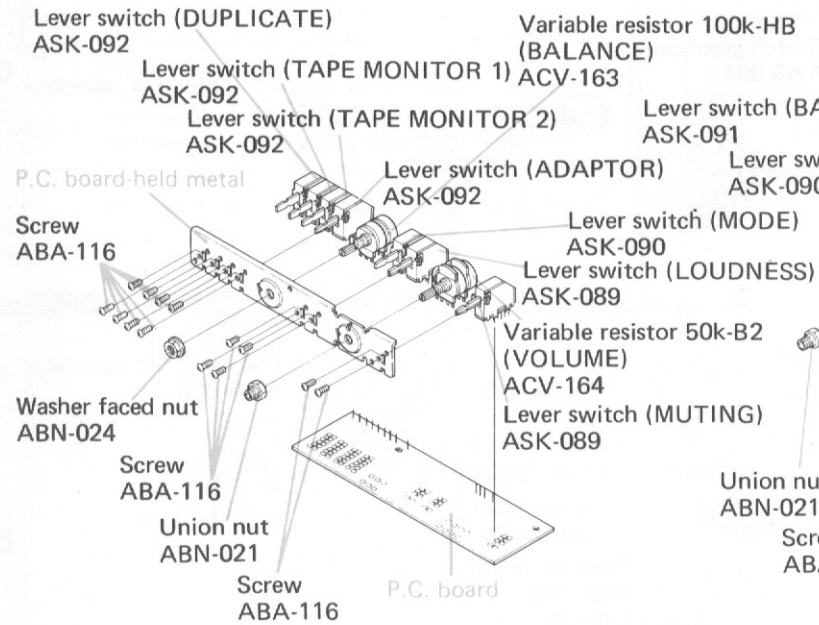

Tone Amplifier Assembly (AWG-039)

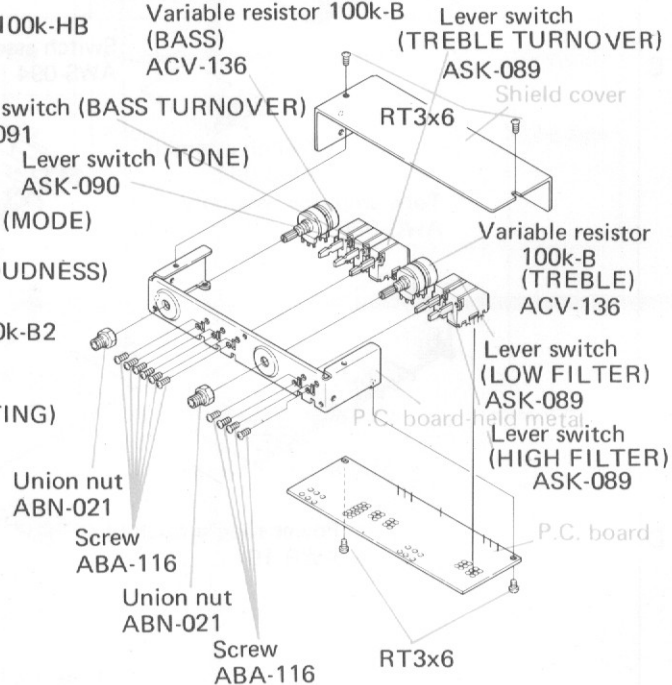

Switch Assembly (AWS-093)

Push switch (FM MUTING, MPX
NOISE FILTER)

ASG-096

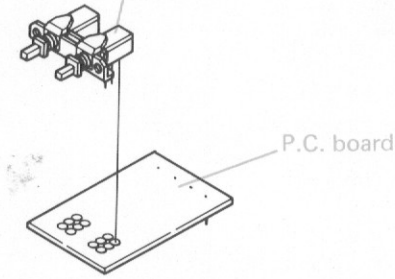

NOTE:

Parts indicated in green type cannot be supplied.

Switch Assembly (AWX-095)

Slide switch (DE-EMPHASIS)
ASH-015

P.C. board

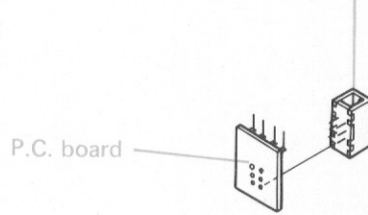

Switch Assembly (AWS-094)

Push switch (AM, FM, PHONO 1,
PHONO 2/MIC, AUX)

ASG-095

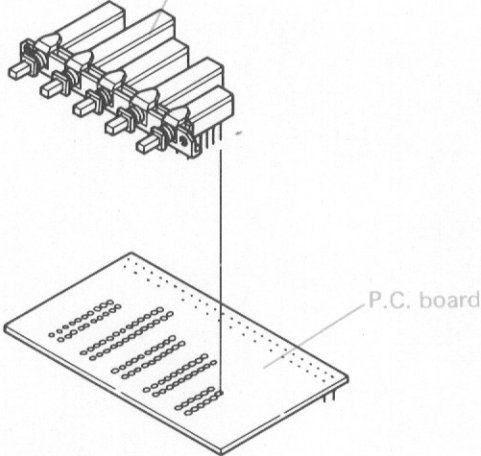

Microphone Jack Assembly (AWX-094)

Phone jack (MIC)
AKN-012

P.C. board

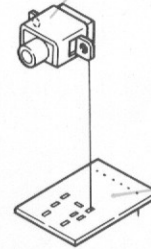

Switch Assembly (AWS-095)

Push switch (SPEAKERS A, B, C)
ASG-094

Phone jack (PHONES)
AKN-010

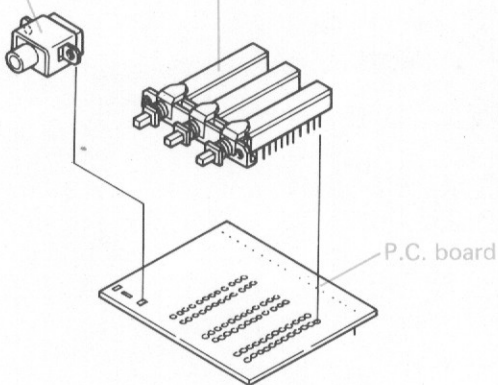

5P Connector Assembly (AWX-062)

5P connector socket (REC/PLAY)
AKP-007

P.C. board

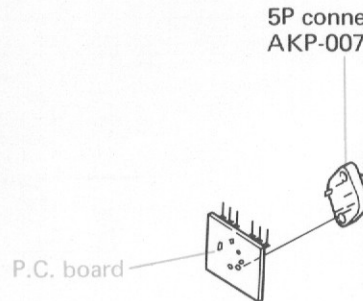

12. SCHEMATIC DIAGRAMS, P.C.BOARD PATTERNS AND PARTS LISTS

12.1 MISCELLANEOUS-PARTS

SEMICONDUCTORS

Symbol	Description	Part No.
Q1	Transistor	2SB557-R
Q2	Transistor	2SB557-R
Q3	Transistor	2SD427-R
Q4	Transistor	2SD427-R
Q5	Transistor	2SB557-R
Q6	Transistor	2SB557-R
Q7	Transistor	2SD427-R
Q8	Transistor	2SD427-R

LAMPS

Symbol	Description	Part No.
PL1	Lamp assembly*	AEL-056
PL2	Lamp assembly*	AEL-056
PL3	Lamp assembly*	AEL-056
PL4	Lamp assembly*	AEL-056
	*Lamp assemblies (PL1-PL4) are made up of the following parts.	
	(1) Lamp (8V, 0.3A, wedge-type)	AEL-029
	(2) Lamp socket (wedge-type)	AKK-004
PL5	Lamp with leads (8V, 50mA)	AEL-069
PL6	Lamp with leads (8V, 50mA)	AEL-076
PL7	Lamp with leads (8V, 50mA)	AEL-075
PL8	Lamp with leads (8V, 50mA)	AEL-074
PL9	Lamp with leads (8V, 50mA)	AEL-072
PL10	Lamp with leads (8V, 50mA)	AEL-073
PL11	Lamp with leads (8V, 50mA)	AEL-074
PL12	Lamp with leads (8V, 50mA)	AEL-072
PL13	Lamp with leads (8V, 50mA)	AEL-073

FUSES

Symbol	Description	Part No.
FU1	Fuse 6A (primary)	AEK-109
FU2	Fuse 1A	AEK-106
FU3	Fuse 1A	AEK-106
FU4	Fuse 1A	AEK-106
FU5	Fuse 1A	AEK-106
FU6	Fuse 1.5A (lamp circuit)	AEK-104

SWITCHES

Symbol	Description	Part No.
S1	Lever switch (POWER)	ASK-080
S2	Relay	ASR-019

NOTE:

- Capacitors: in μF unless otherwise noted p:pF
- Resistors: in Ω , $\frac{1}{4}W$ unless otherwise noted k:k Ω , M:M Ω

TRANSFORMERS AND COILS

Symbol	Description	Part No.
T1	Power transformer	ATT-265
T2	Ferrite balun	T22-025
T3	Ferrite bar-antenna	ATB-046

RESISTORS

Symbol	Description	Part No.
R1	Metal oxide 2.7k 2W	RS2P 272J
R2	Metal oxide 2.7k 2W	RS2P 272J
R3	Carbon film 2.2M $\frac{1}{2}W$	RD $\frac{1}{2}$ PS 225J

CAPACITORS

Symbol	Description	Part No.
C1	Electrolytic 22,000 63V	ACH-059
C2	Electrolytic 22,000 63V	ACH-059
C3	Ceramic 0.01 150V (DC1.4kV)	ACG-003
C4	Ceramic 0.01 150V (DC1.4kV)	ACG-003
C5	Ceramic 0.01 50V	CKDYF 103Z 50
C6	Ceramic 0.01 50V	CKDYF 103Z 50
C7	Ceramic 0.01 50V	CKDYF 103Z 50
C8	Ceramic 0.01 50V	CKDYF 103Z 50
C9	Ceramic 0.01 50V	CKDYF 103Z 50
C10	Ceramic 0.01 50V	CKDYF 103Z 50
C11	Ceramic 0.01 50V	CKDYF 103Z 50
C12	Ceramic 0.01 50V	CKDYF 103Z 50

12.2 SCHEMATIC DIAGRAM

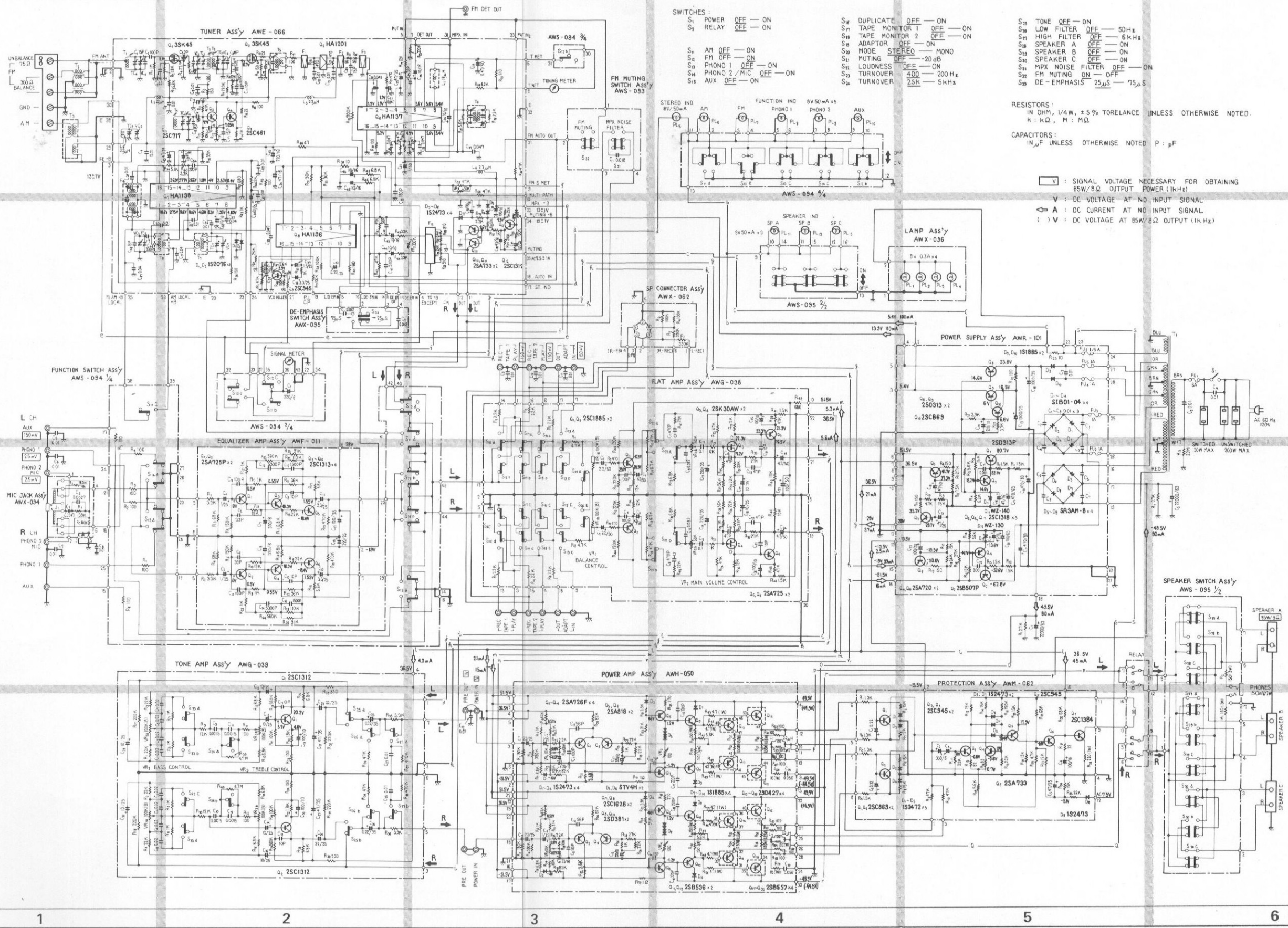

Circuit Diagrams of ICs

HA1137 (FM IF IC)

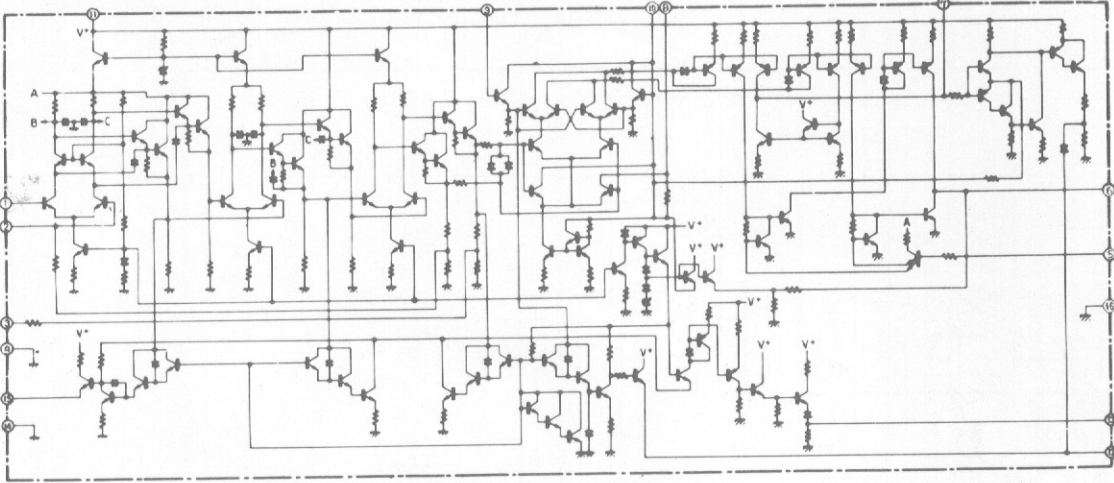

HA1138 (AM IC)

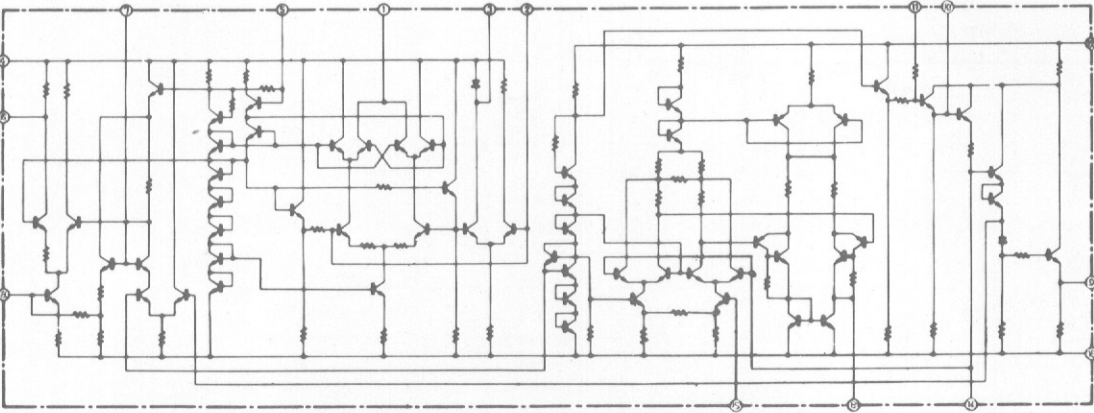

HA1196

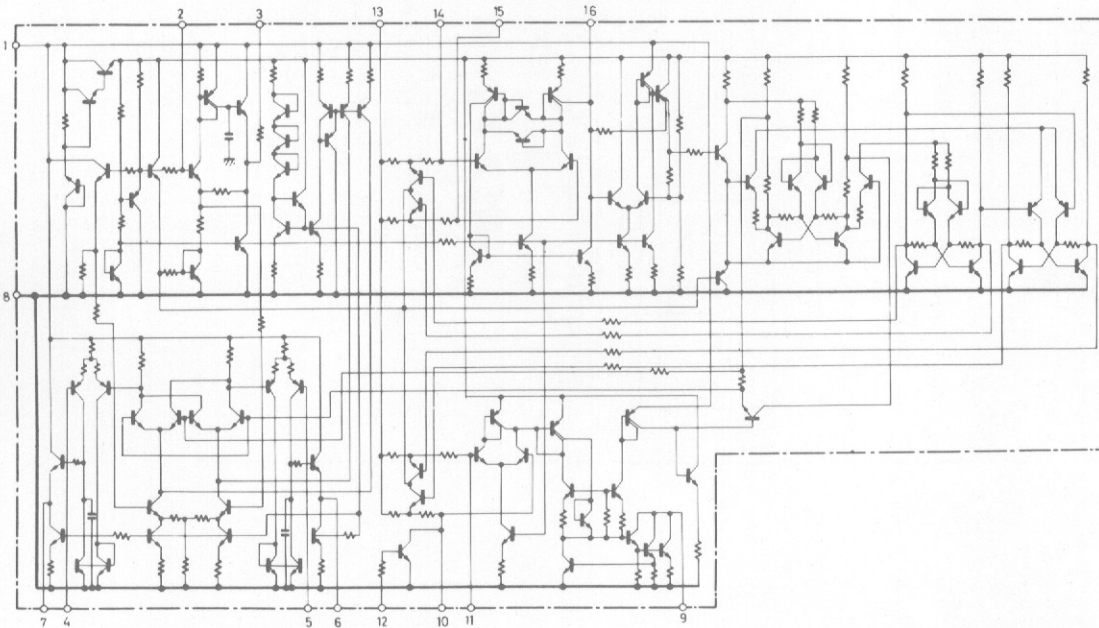

HA1201

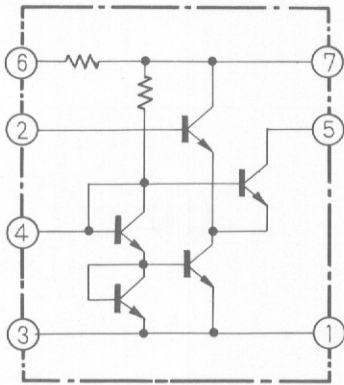

External Appearance of Transistors and ICs

2SA725
(2SA763P)
2SA726S
(2SA763P)
2SC869
(2SC857)
(2SC1515)
2SC1312
2SC1313
(2SC1345)

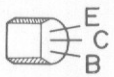

2SC461
2SC717

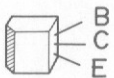

2SA720
2SA733
2SC945
2SC945A
2SC1318

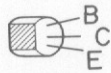

2SB507P
2SB536
2SD313
2SD313P
2SD381

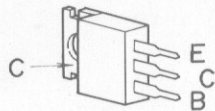

2SC1384
2SC1885

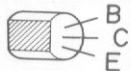

2SK30AW



3SK45

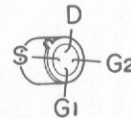

2SA818
(2SB527)
2SC1628
(2SC1451)

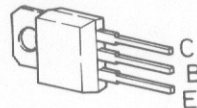

2SB557
2SD427

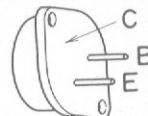

HA1201

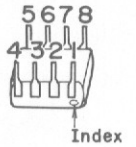

HA1137
HA1138
HA1196

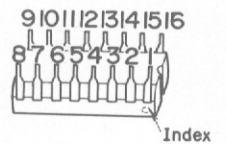

12.3 TUNER ASSEMBLY (AWE-066)

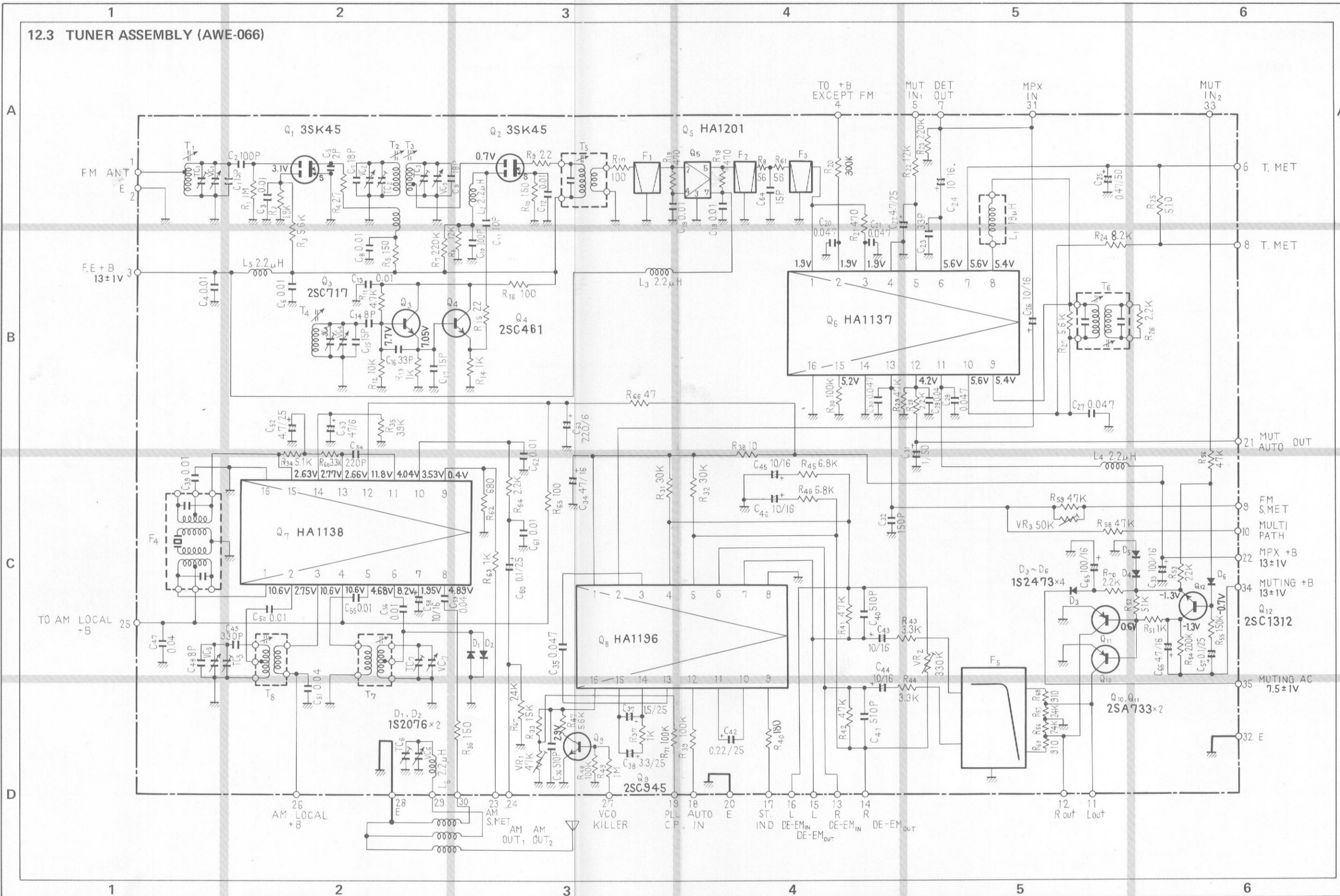

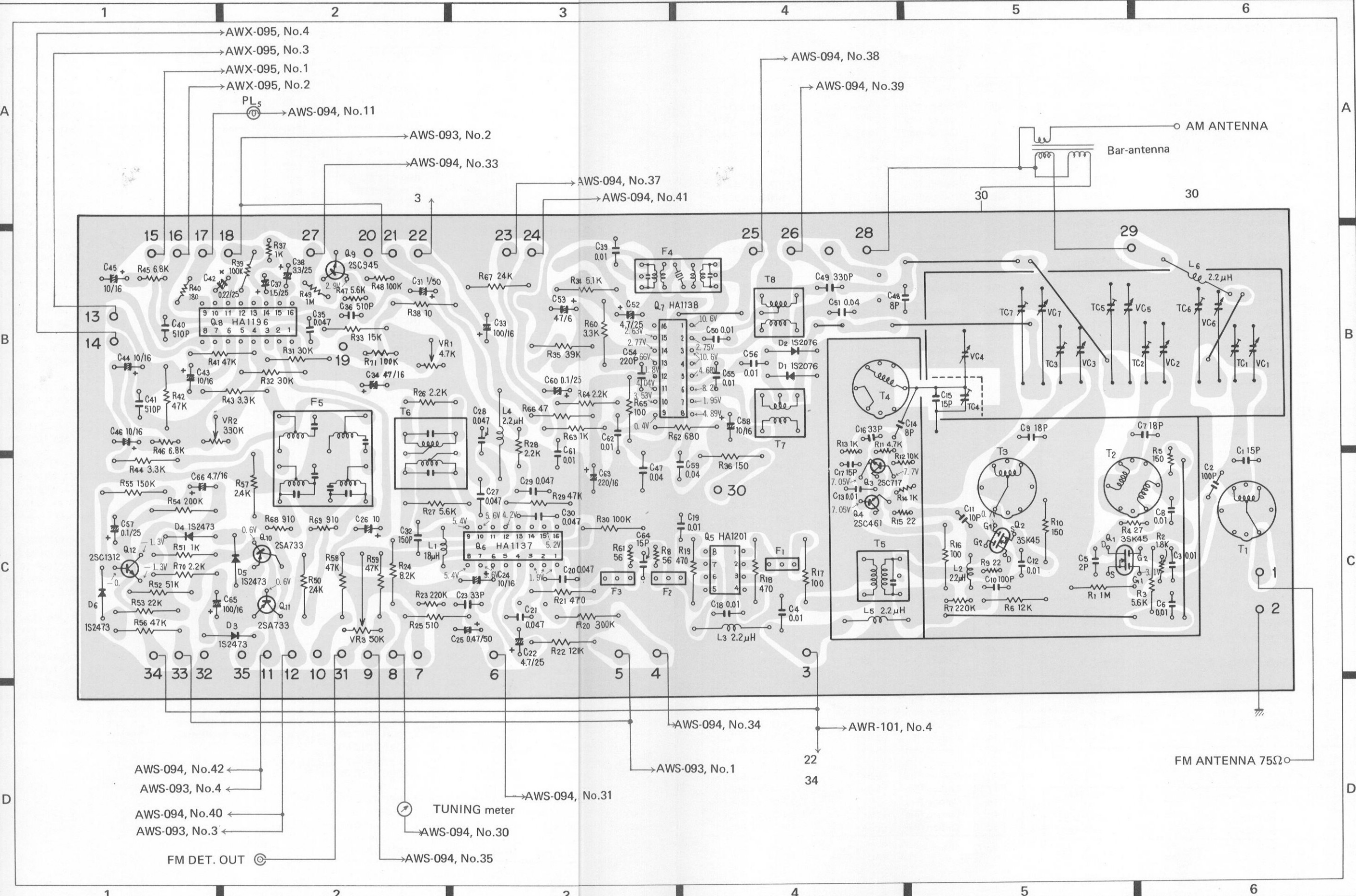

- AWX-095, No.4
- AWX-095, No.3
- AWX-095, No.1
- AWX-095, No.2

- AWS-094, No.38
- AWS-094, No.39

- AWS-094, No.11
- AWS-093, No.2
- AWS-094, No.33

- AWS-094, No.37
- AWS-094, No.41

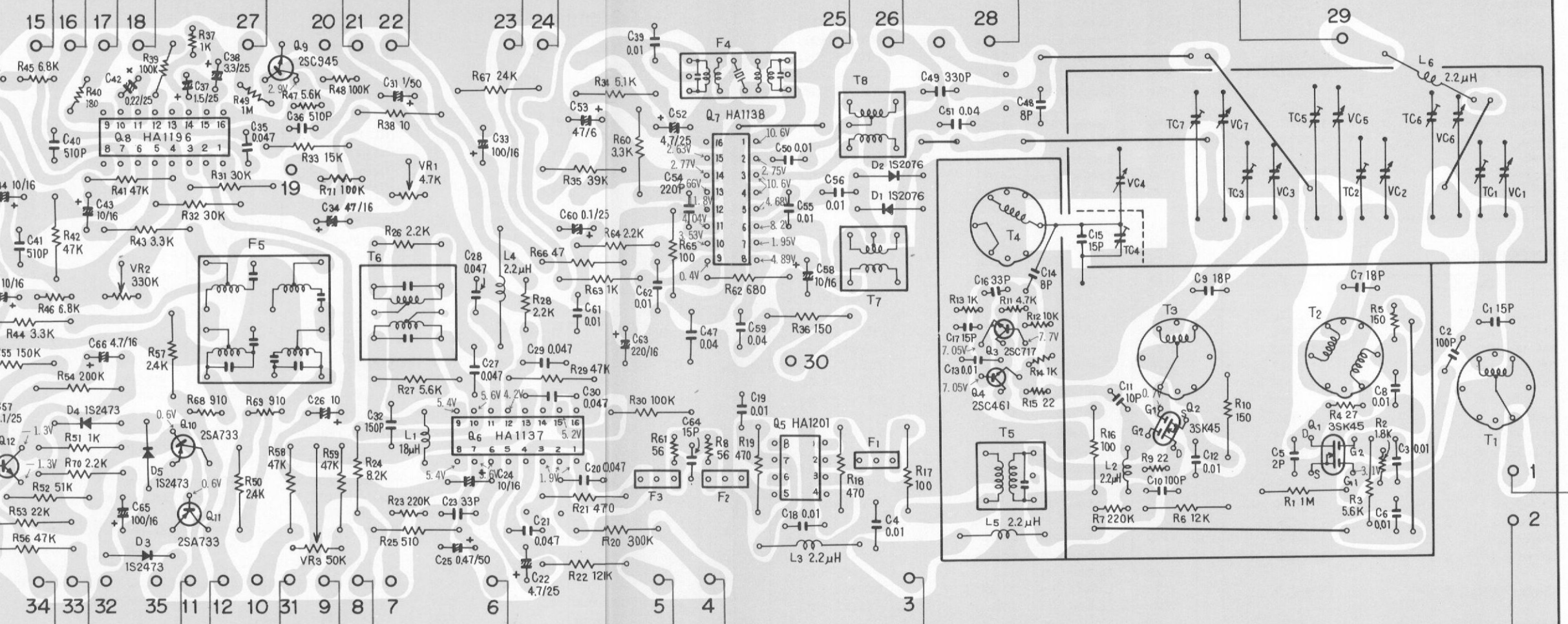

- AWS-094, No.42
- AWS-093, No.4
- AWS-094, No.40
- AWS-093, No.3

- TUNING meter
- AWS-094, No.30
- AWS-094, No.35

- AWS-094, No.34
- AWR-101, No.4
- AWS-093, No.1
- AWS-094, No.31

FM ANTENNA 75Ω

Parts List of Tuner Assembly (AWE-066)

SEMICONDUCTORS

Symbol	Description	Part No.
Q1	FET	3SK45-B
Q2	FET	3SK45-B
Q3	Transistor	2SC717
Q4	Transistor	2SC461-B
Q5	IC	HA1201
Q6	IC	HA1137
Q7	IC	HA1138
Q8	IC	HA1196
Q9	Transistor	2SC945A-Q
Q10	Transistor	2SA733-Q
Q11	Transistor	2SA733-Q
Q12	Transistor	2SC1312-G
D1	Diode	1S2076
D2	Diode	1S2076
D3	Diode	1S2473
D4	Diode	1S2473
D5	Diode	1S2473
D6	Diode	1S2473

COILS, TRANSFORMERS

Symbol	Description	Part No.
T1	FM antenna coil	ATC-021
T2	FM RF coil	ATC-015
T3	FM RF coil	ATC-016
T4	FM oscillator coil	ATC-022
T5	FM IFT	ATE-008
T6	FM IFT	T73-035
T7	AM RF coil	ATB-014
T8	AM oscillator coil	ATB-013
L1	Choke coil 18 μ H	ATH-007
L2	Choke coil 2.2 μ H	T24-028
L3	Choke coil 2.2 μ H	T24-028
L4	Choke coil 2.2 μ H	T24-028
L5	Choke coil 2.2 μ H	T24-028
L6	Choke coil 2.2 μ H	T24-028
F1	FM ceramic filter	ATF-013
F2	FM ceramic filter	ATF-013
F3	FM ceramic filter	ATF-013
F4	AM ceramic filter	ATF-027
F5	Low pass filter	ATF-033

RESISTORS

Symbol	Description	Part No.
R1	Carbon film 1M	RD $\frac{1}{2}$ PS 105J
R2	Carbon film 1.8k	RD $\frac{1}{2}$ VS 182J

Symbol	Description	Part No.
R3	Carbon film 5.6k	RD $\frac{1}{2}$ PS 562J
R4	Carbon film 27	RD $\frac{1}{2}$ VS 270J
R5	Carbon film 150	RD $\frac{1}{2}$ VS 151J
R6	Carbon film 12k	RD $\frac{1}{2}$ PS 123J
R7	Carbon film 220k	RD $\frac{1}{2}$ VS 224J
R8	Carbon film 56	RD $\frac{1}{2}$ VS 560J
R9	Carbon film 22	RD $\frac{1}{2}$ VS 220J
R10	Carbon film 150	RD $\frac{1}{2}$ PS 151J
R11	Carbon film 4.7k	RD $\frac{1}{2}$ VS 472J
R12	Carbon film 10k	RD $\frac{1}{2}$ VS 103J
R13	Carbon film 1k	RD $\frac{1}{2}$ VS 102J
R14	Carbon film 1k	RD $\frac{1}{2}$ VS 102J
R15	Carbon film 22	RD $\frac{1}{2}$ VS 220J
R16	Carbon film 100	RD $\frac{1}{2}$ PS 101J
R17	Carbon film 100	RD $\frac{1}{2}$ PS 101J
R18	Carbon film 470	RD $\frac{1}{2}$ PS 471J
R19	Carbon film 470	RD $\frac{1}{2}$ PS 471J
R20	Carbon film 300k	RD $\frac{1}{2}$ PS 304J
R21	Carbon film 470	RD $\frac{1}{2}$ PS 471J
R22	Carbon film 12k	RD $\frac{1}{2}$ PS 123J
R23	Carbon film 220k	RD $\frac{1}{2}$ VS 224J
R24	Carbon film 8.2k	RD $\frac{1}{2}$ PS 822J
R25	Carbon film 510	RD $\frac{1}{2}$ PS 511J
R26	Carbon film 2.2k	RD $\frac{1}{2}$ VS 222J
R27	Carbon film 5.6k	RD $\frac{1}{2}$ PS 562J
R28	Carbon film 2.2k	RD $\frac{1}{2}$ VS 222J
R29	Carbon film 47k	RD $\frac{1}{2}$ PS 473J
R30	Carbon film 100k	RD $\frac{1}{2}$ PS 104J
R31	Carbon film 30k	RD $\frac{1}{2}$ PS 303J
R32	Carbon film 30k	RD $\frac{1}{2}$ PS 303J
R33	Carbon film 15k	RD $\frac{1}{2}$ PS 153J
R34	Carbon film 5.1k	RD $\frac{1}{2}$ PS 512J
R35	Carbon film 39k	RD $\frac{1}{2}$ PS 393J
R36	Carbon film 150	RD $\frac{1}{2}$ PS 151J
R37	Carbon film 1k	RD $\frac{1}{2}$ VS 102J
R38	Carbon film 10	RD $\frac{1}{2}$ PS 100J
R39	Carbon film 100k	RD $\frac{1}{2}$ VS 104J
R40	Carbon film 180	RD $\frac{1}{2}$ VS 181J
R41	Carbon film 47k	RD $\frac{1}{2}$ PS 473J
R42	Carbon film 47k	RD $\frac{1}{2}$ PS 473J
R43	Carbon film 3.3k	RD $\frac{1}{2}$ PS 332J
R44	Carbon film 3.3k	RD $\frac{1}{2}$ PS 332J
R45	Carbon film 6.8k	RD $\frac{1}{2}$ PS 682J
R46	Carbon film 6.8k	RD $\frac{1}{2}$ VS 682J
R47	Carbon film 5.6k	RD $\frac{1}{2}$ VS 562J
R48	Carbon film 100k	RD $\frac{1}{2}$ VS 104J
R49	Carbon film 1M	RD $\frac{1}{2}$ VS 105J
R50	Carbon film 2.4k	RD $\frac{1}{2}$ PS 242J

Symbol	Description	Part No.
R51	Carbon film 1k	RD¼PS 102J
R52	Carbon film 51k	RD¼PS 513J
R53	Carbon film 22k	RD¼PS 223J
R54	Carbon film 200k	RD¼PS 204J
R55	Carbon film 150k	RD¼PS 154J
R56	Carbon film 47k	RD¼PS 473J
R57	Carbon film 2.4k	RD¼PS 242J
R58	Carbon film 47k	RD¼PS 473J
R59	Carbon film 47k	RD¼PS 473J
R60	Carbon film 3.3k	RD¼PS 332J
R61	Carbon film 56	RD¼VS 560J
R62	Carbon film 680	RD¼PS 681J
R63	Carbon film 1k	RD¼PS 102J
R64	Carbon film 2.2k	RD¼PS 222J
R65	Carbon film 100	RD¼PS 101J
R66	Carbon film 47	RD¼PS 470J
R67	Carbon film 24k	RD¼PS 243J
R68	Carbon film 910	RD¼VS 911J
R69	Carbon film 910	RD¼VS 911J
R70	Carbon film 2.2k	RD¼PS 222J
R71	Carbon film 100k	RD¼VS 104J
VR1	Semi-fixed 4.7k-B	C92-051
VR2	Semi-fixed 330k-B	ACP-042
VR3	Semi-fixed 50k-B	ACP-043

CAPACITORS

Symbol	Description	Part No.
C1	Ceramic 15p 50V	CCDSH 150K 50
C2	Ceramic 100p 50V	CCDSL 101K 50
C3	Ceramic 0.01 50V	CKDYF 103Z 50
C4	Ceramic 0.01 50V	CKDYF 103Z 50
C5	Ceramic 2p 50V	CCDSL 020C 50
C6	Ceramic 0.01 50V	CKDYF 103Z 50
C7	Ceramic 18p 50V	CCDSH 180K 50
C8	Ceramic 0.01 50V	CKDYF 103Z 50
C9	Ceramic 18p 50V	CCDSH 180K 50
C10	Ceramic 100p 50V	CCDSL 101K 50
C11	Ceramic 10p 50V	CCDSL 100F 50
C12	Ceramic 0.01 50V	CKDYF 103Z 50
C13	Ceramic 0.01 50V	CKDYB 103K 50
C14	Ceramic 8p 50V	CCDLH 080F 50
C15	Ceramic 15p 50V	CCDLH 150K 50
C16	Ceramic 33p 50V	CCDCH 330K 50
C17	Ceramic 15p 50V	CCDCH 150K 50
C18	Ceramic 0.01 50V	CKDYF 103Z 50
C19	Ceramic 0.01 50V	CKDYF 103Z 50
C20	Ceramic 0.047 25V	CKDBC 473Z 25
C21	Ceramic 0.047 25V	CKDBC 473Z 25
C22	Electrolytic 4.7 25V	CEA 4R7P 25
C23	Ceramic 33p 50V	CCDSL 330K 50
C24	Electrolytic 10 16V	CEA 100P 16
C25	Electrolytic 0.47 50V	CEA 4R7P 50

Symbol	Description	Part No.
C26	Electrolytic 10 16V	CEA 100P 16
C27	Ceramic 0.047 25V	CKDBC 473Z 25
C28	Ceramic 0.047 25V	CKDBC 473Z 25
C29	Ceramic 0.047 25V	CKDBC 473Z 25
C30	Ceramic 0.047 25V	CKDBC 473Z 25
C31	Electrolytic 1 50V	CEA 010P 50
C32	Ceramic 150p 50V	CCDSL 151K 50
C33	Electrolytic 100 16V	CEA 101P 16
C34	Electrolytic 47 16V	CEA 470P 16
C35	Mylar 0.047 50V	CQMA 473K 50
C36	Styrol 510p 50V	CQSA 511J 50
C37	Electrolytic 1.5 25V	CSZA 1R5M 25
C38	Electrolytic 3.3 25V	CSZA 3R3M 25
C39	Ceramic 0.01 50V	CKDYB 103K 50
C40	Styrol 510p 50V	CQSA 511J 50
C41	Styrol 510p 50V	CQSA 511J 50
C42	Electrolytic 0.22 25V	CSSA 2R2M 25
C43	Electrolytic 10 16V	CEA 100P 16
C44	Electrolytic 10 16V	CEA 100P 16
C45	Electrolytic 10 16V	CEA 100P 16
C46	Electrolytic 10 16V	CEA 100P 16
C47	Ceramic 0.04 50V	CKDYF 403Z 50
C48	Ceramic 8p 50V	CCDXL 080F 50
C49	Styrol 330p 50V	CQSA 331J 50
C50	Mylar 0.01 50V	CQMA 103K 50
C51	Ceramic 0.04 50V	CKDYF 403Z 50
C52	Electrolytic 4.7 25V	CEA 4R7P 25
C53	Electrolytic 47 6V	CEA 470P 6
C54	Ceramic 220p 50V	CCDSL 221K 50
C55	Ceramic 0.01 50V	CKDYF 103Z 50
C56	Ceramic 0.01 50V	CKDYF 103Z 50
C57	Electrolytic 0.1 25V	CSSA 0R1M 25
C58	Electrolytic 10 16V	CEA 100P 16
C59	Ceramic 0.04 50V	CKDYF 403Z 50
C60	Electrolytic 0.1 25V	CSSA 0R1M 25
C61	Ceramic 0.01 50V	CKDYB 103K 50
C62	Ceramic 0.01 50V	CKDYB 103K 50
C63	Electrolytic 220 16V	CEA 221P 16
C64	Ceramic 15p 50V	CCDSL 150K 50
C65	Electrolytic 100 16V	CEA 101P 16
C66	Electrolytic 4.7 16V	CEA 4R7P 16
VC	Tuning capacitor	ACK-016
TC4	Ceramic trimmer	C43-007

12.4 MICROPHONE JACK ASSEMBLY (AWX-094)

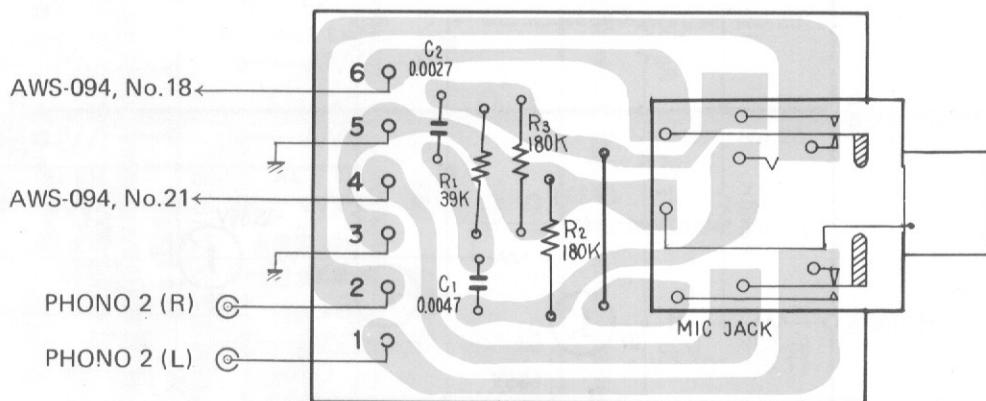
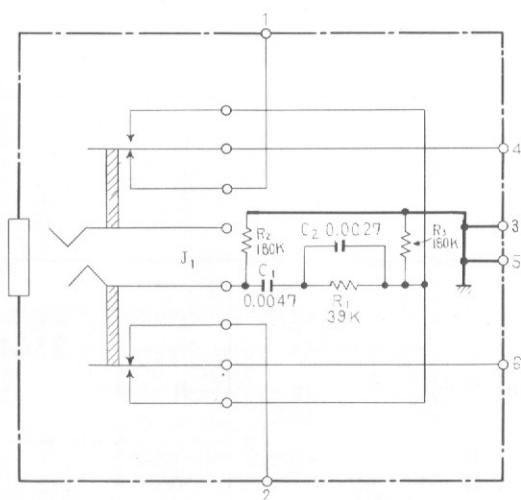

Parts List of Microphone Jack Assembly (AWX-094)

Symbol	Description	Part No.
R1	Carbon film resistor 39k	RD¼PS 393J
R2	Carbon film resistor 180k	RD¼PS 184J
R3	Carbon film resistor 180k	RD¼PS 184J
C1	Mylar capacitor 0.0047 50V	CQMA 472K 50
C2	Mylar capacitor 0.0027 50V	CQMA 272K 50
J1	Jack (MIC)	AKN-012

12.5 EQUALIZER AMPLIFIER ASSEMBLY (AWF-011)

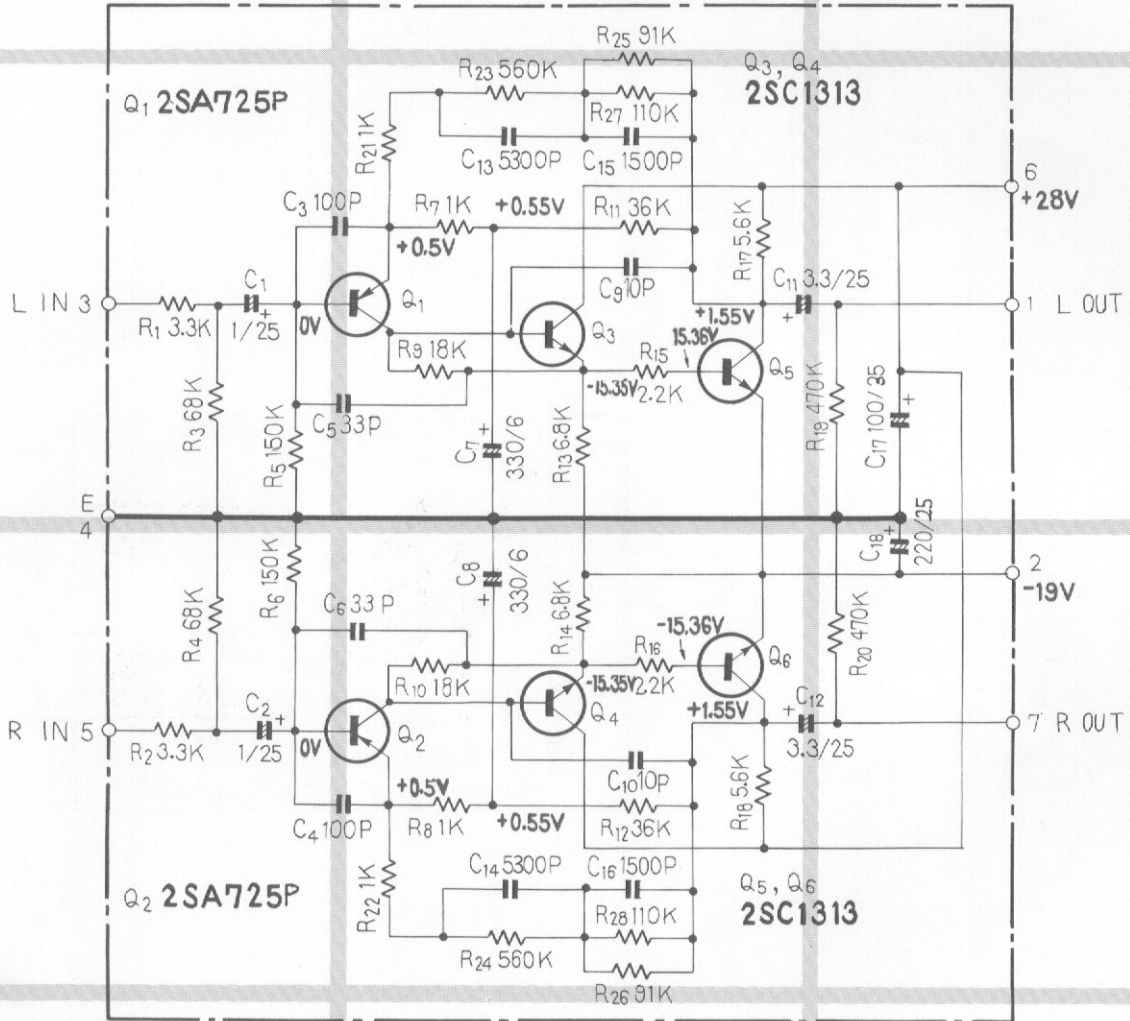

1

2

3

A

A

B

B

C

C

D

D

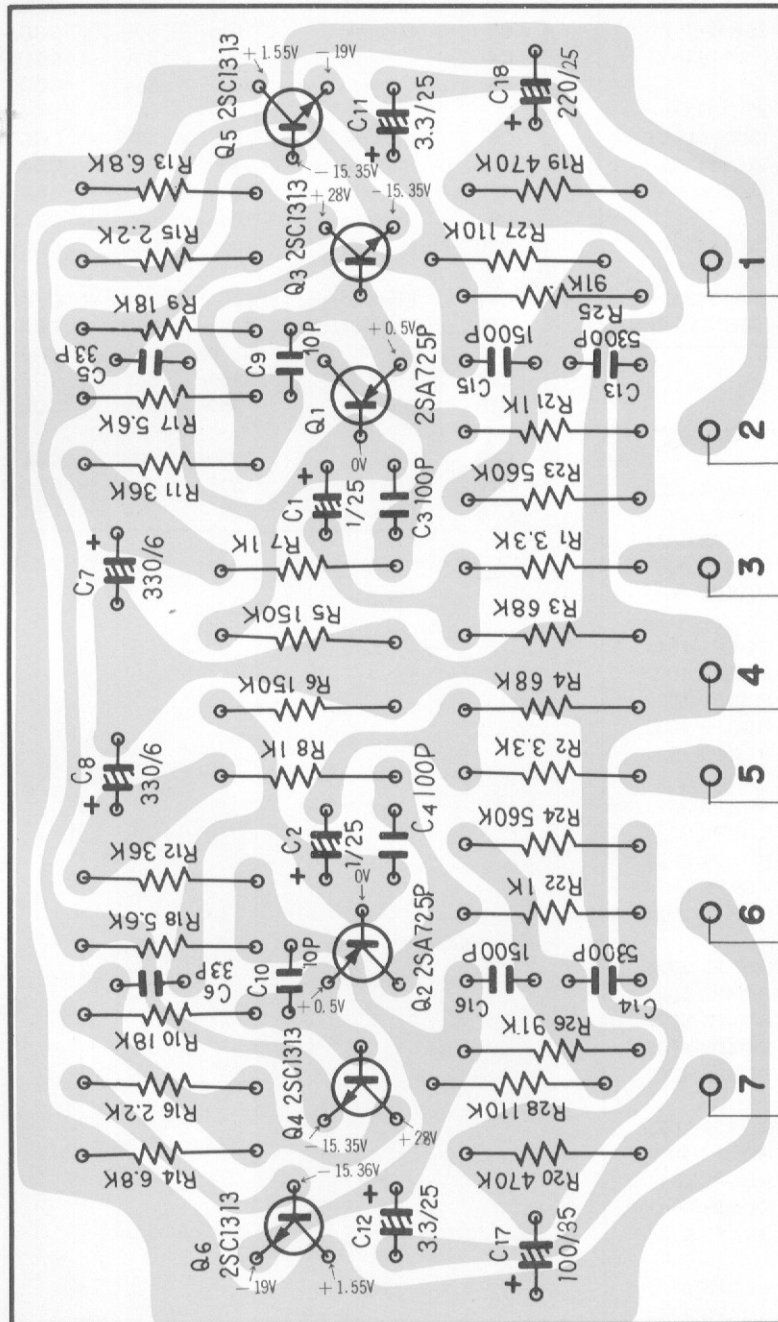

→ AWS-094, No.23

→ AWR-101, No.15

→ AWS-094, No.20

→ AWS-094, No.28

→ AWS-094, No.19

→ AWR-101, No.11

→ AWS-094, No.29

1

2

3

Parts List of Equalizer Amplifier Assembly (AWF-011)

SEMICONDUCTORS

Symbol	Description	Part No.
Q1	Transistor	2SA725P-F (2SA763P-5)
Q2	Transistor	2SA725P-F (2SA763P-5)
Q3	Transistor	2SC1313-G (2SC1345-E)
Q4	Transistor	2SC1313-G (2SC1345-E)
Q5	Transistor	2SC1313-G (2SC1345-E)
Q6	Transistor	2SC1313-G (2SC1345-E)

RESISTORS

Symbol	Description	Part No.
R1	Carbon film 3.3k	RD½PS 332J
R2	Carbon film 3.3k	RD½PS 332J
R3	Carbon film 68k	RD½PS 683J
R4	Carbon film 68k	RD½PS 683J
R5	Carbon film 150k	RD½PS 154J
R6	Carbon film 150k	RD½PS 154J
R7	Carbon film 1k	RD½PS 102J
R8	Carbon film 1k	RD½PS 102J
R9	Carbon film 18k	RD½PS 183J
R10	Carbon film 18k	RD½PS 183J
R11	Carbon film 36k	RD½PS 363J
R12	Carbon film 36k	RD½PS 363J
R13	Carbon film 6.8k	RD½PS 682J
R14	Carbon film 6.8k	RD½PS 682J
R15	Carbon film 2.2k	RD½PS 222J
R16	Carbon film 2.2k	RD½PS 222J
R17	Carbon film 5.6k	RD½PS 562J
R18	Carbon film 5.6k	RD½PS 562J
R19	Carbon film 470k	RD½PS 474J
R20	Carbon film 470k	RD½PS 474J
R21	Carbon film 1k	RD½PS 102J
R22	Carbon film 1k	RD½PS 102J
R23	Carbon film 560k	RD½PS 564JNL
R24	Carbon film 560k	RD½PS 564JNL
R25	Carbon film 91k	RD½PS 913J
R26	Carbon film 91k	RD½PS 913J
R27	Carbon film 110k	RD½PS 114J
R28	Carbon film 110k	RD½PS 114J

CAPACITORS

Symbol	Description	Part No.
C1	Electrolytic 1 25V	CSSA 010M 25
C2	Electrolytic 1 25V	CSSA 010M 25
C3	Ceramic 100p 50V	CCDSL 101K 50
C4	Ceramic 100p 50V	CCDSL 101K 50
C5	Ceramic 33p 50V	CCDSL 330K 50
C6	Ceramic 33p 50V	CCDSL 330K 50
C7	Electrolytic 330 6V	CEA 331P 6
C8	Electrolytic 330 6V	CEA 331P 6
C9	Ceramic 10p 50V	CCDSL 100K 50
C10	Ceramic 10p 50V	CCDSL 100K 50
C11	Electrolytic 3.3 25V	CEANL 3R3P 25
C12	Electrolytic 3.3 25V	CEANL 3R3P 25
C13	Styrol 5300p 50V	CQSA 532G 50
C14	Styrol 5300p 50V	CQSA 532G 50
C15	Styrol 1500p 50V	CQSA 152G 50
C16	Styrol 1500p 50V	CQSA 152G 50
C17	Electrolytic 100 35V	CEA 101P 35
C18	Electrolytic 220 25V	CEA 221P 25

12.6 5P CONNECTOR ASSEMBLY (AWX-062)

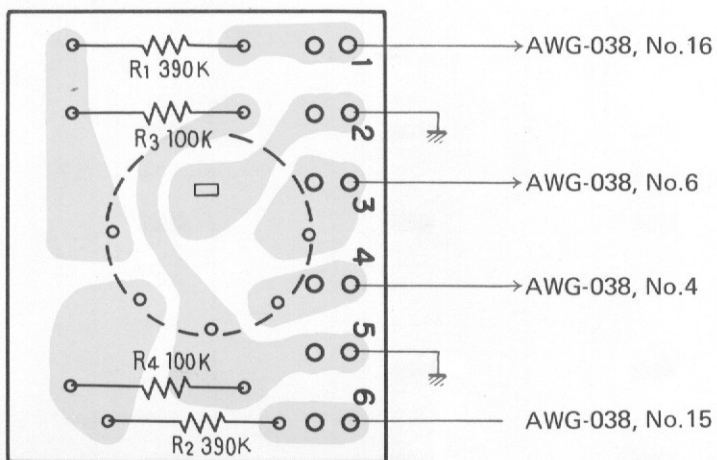
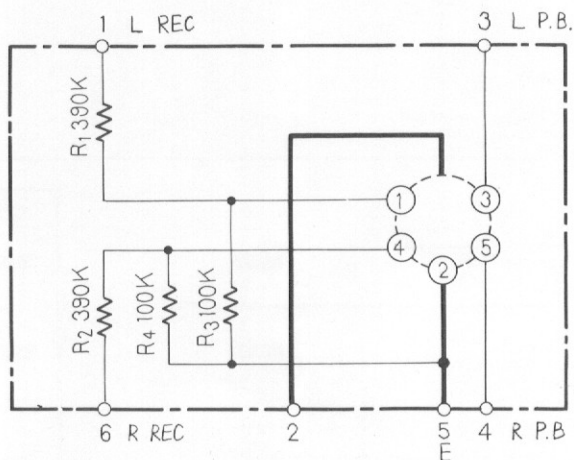

Parts List of 5P Connector Assembly (AWX-062)

Symbol	Description	Part No.
R1	Carbon film resistor 390k	RD¼PS 394J
R2	Carbon film resistor 390k	RD¼PS 394J
R3	Carbon film resistor 100k	RD¼PS 104J
R4	Carbon film resistor 100k	RD¼PS 104J
	Connector socket 5P (REC/PLAY)	AKP-007

12.7 SWITCH ASSEMBLY (AWS-094)

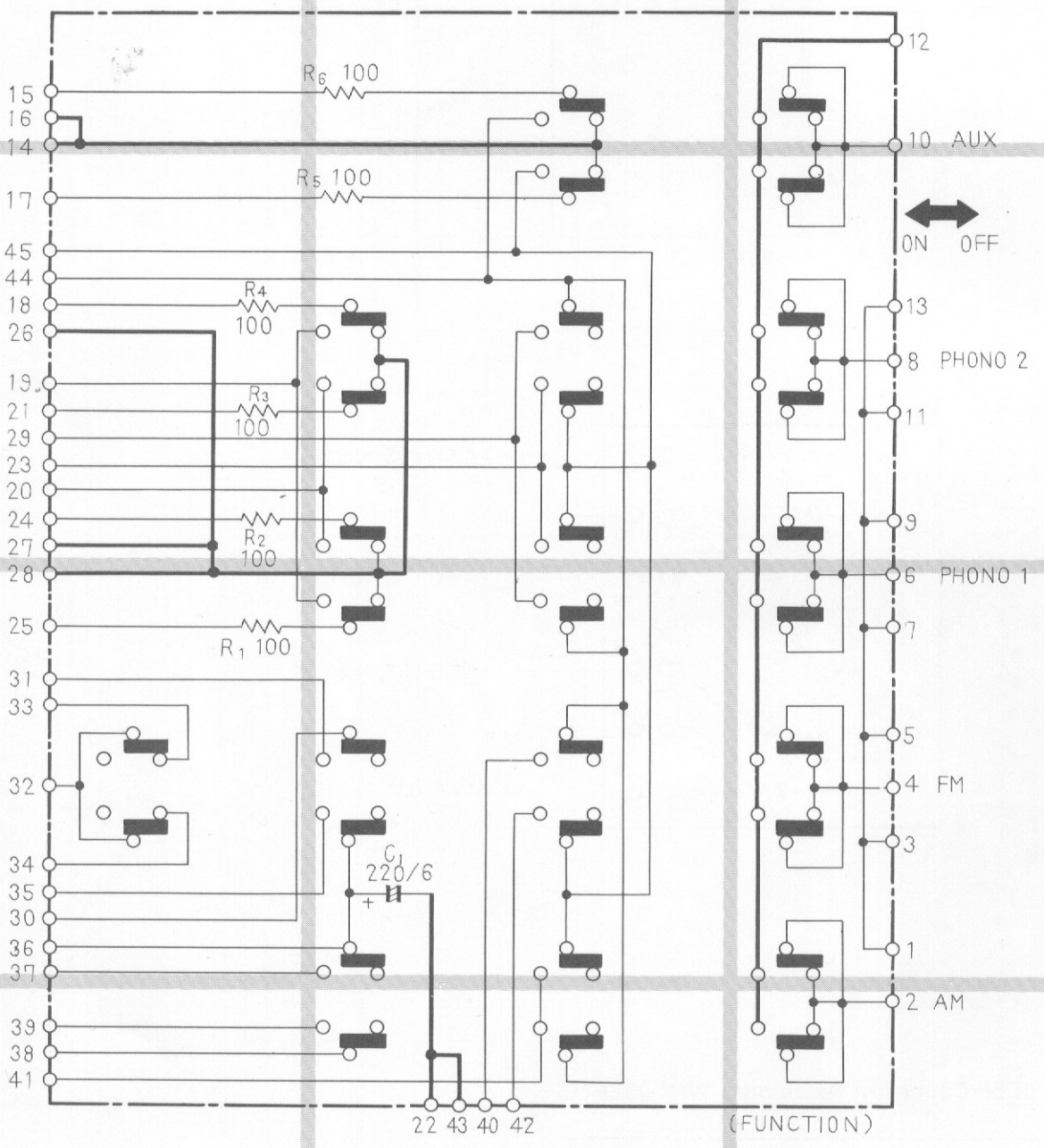

Parts List of Switch Assembly (AWS-094)

Symbol	Description	Part No.
S1	Push switch (FUNCTION)	ASG-095
R1	Carbon film resistor 100	RD¼PS 101J
R2	Carbon film resistor 100	RD¼PS 101J
R3	Carbon film resistor 100	RD¼PS 101J
R4	Carbon film resistor 100	RD¼PS 101J
R5	Carbon film resistor 100	RD¼PS 101J
R6	Carbon film resistor 100	RD¼PS 101J
C1	Electrolytic capacitor 220 6V	CEA 221P 6

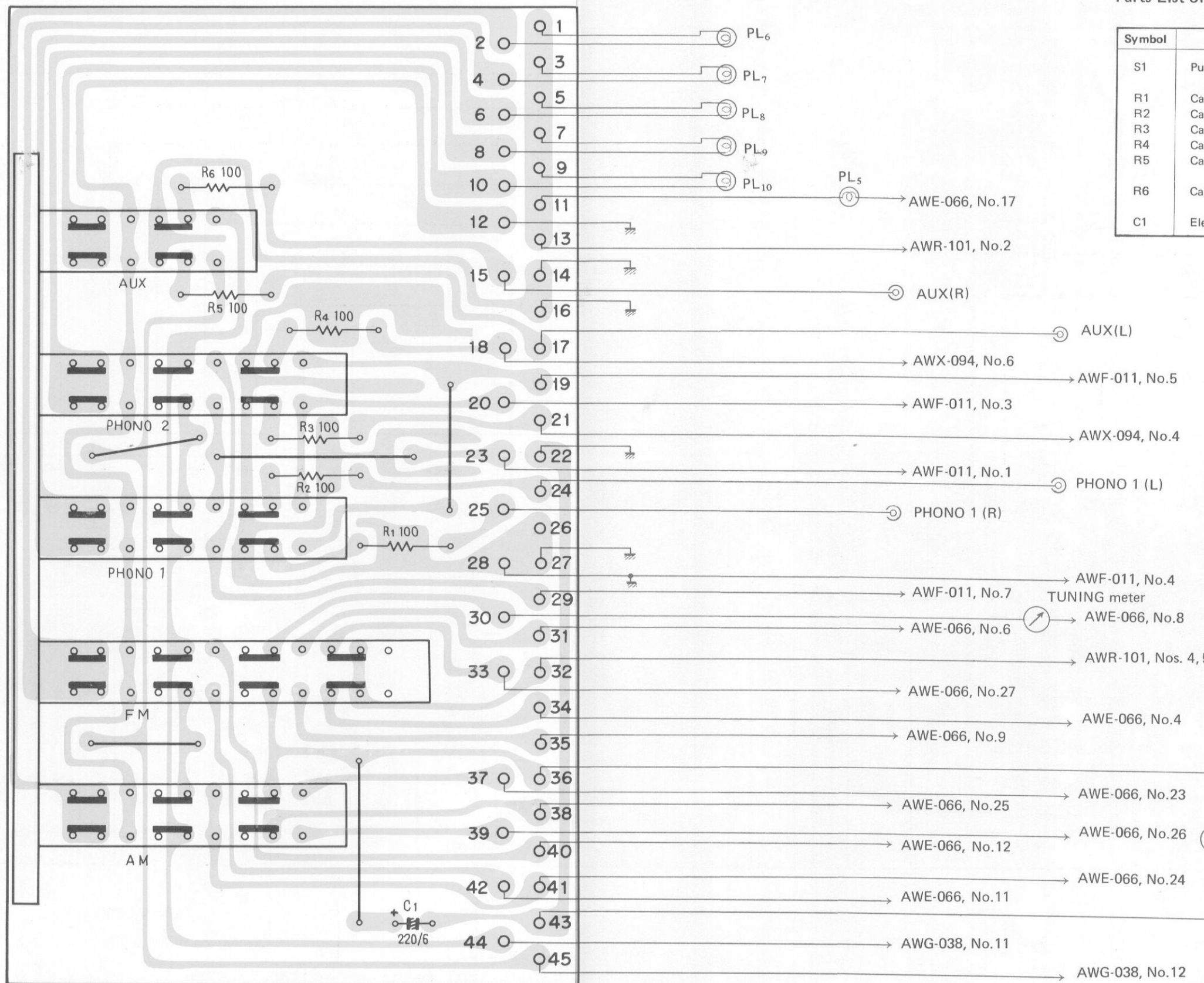

SIGNAL meter

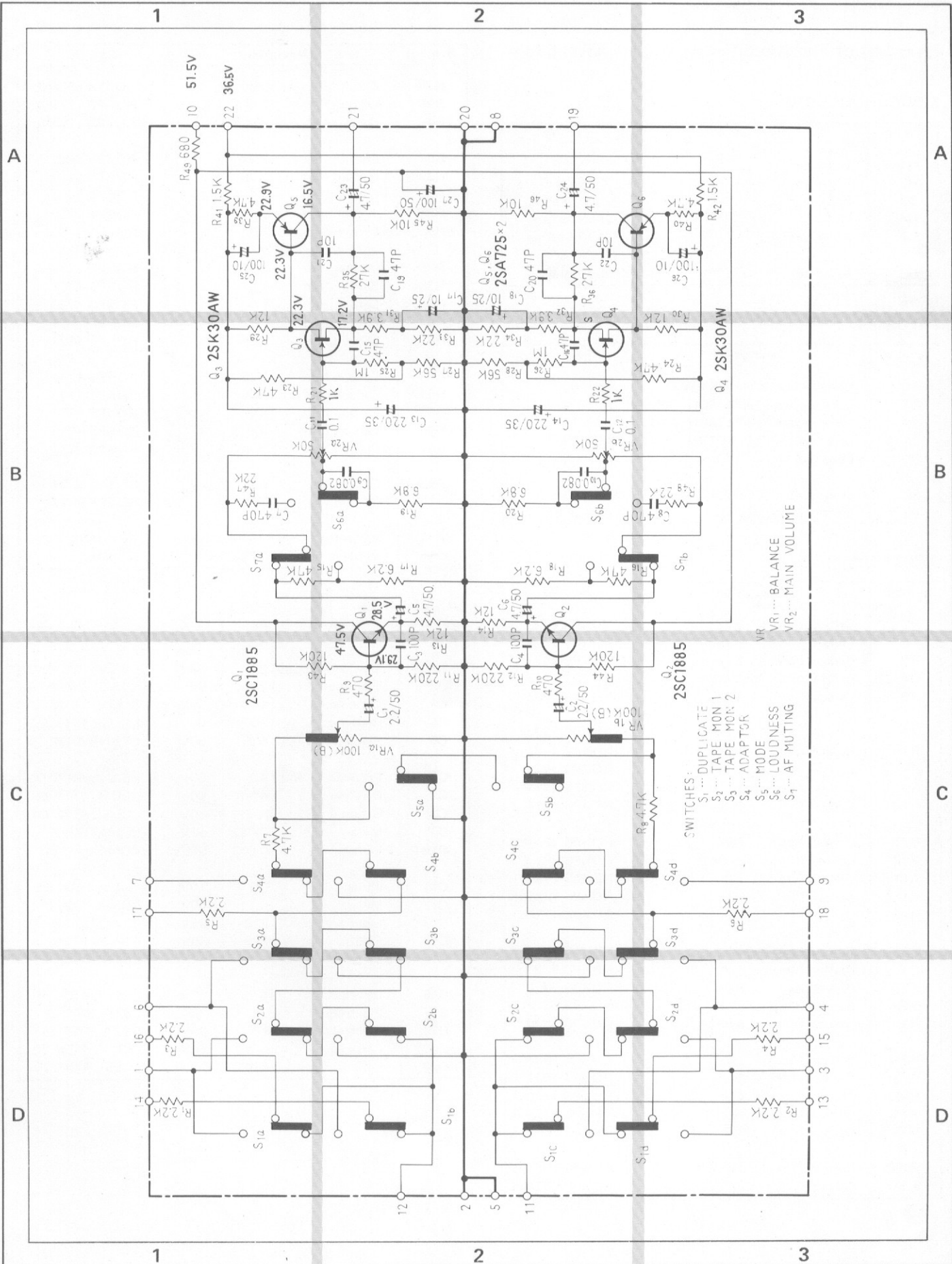

Parts List of Flat Amplifier Assembly (AWG-038)

SEMICONDUCTORS

Symbol	Description	Part No.
Q1	Transistor	2SC1885-R
Q2	Transistor	2SC1885-R
Q3	FET	2SK30AW-Y
Q4	FET	2SK30AW-Y
Q5	Transistor	2SA725-F
Q6	Transistor	2SA725-F

SWITCHES

Symbol	Description	Part No.
S1	Lever switch (DUPLICATE)	ASK-092
S2	Lever switch (TAPE MONITOR 1)	ASK-092
S3	Lever switch (TAPE MONITOR 2)	ASK-092
S4	Lever switch (ADAPTOR)	ASK-092
S5	Lever switch (MODE)	ASK-090
S6	Lever switch (LOUDNESS)	ASK-089
S7	Lever switch (MUTING)	ASK-089

RESISTORS

Symbol	Description	Part No.
R1	Carbon film 2.2k	RD½PS 222J
R2	Carbon film 2.2k	RD½PS 222J
R3	Carbon film 2.2k	RD½PS 222J
R4	Carbon film 2.2k	RD½PS 222J
R5	Carbon film 2.2k	RD½PS 222J
R6	Carbon film 2.2k	RD½PS 222J
R7	Carbon film 4.7k	RD½PS 472J
R8	Carbon film 4.7k	RD½PS 472J
R9	Carbon film 470	RD½PS 471J
R10	Carbon film 470	RD½PS 471J
R11	Carbon film 220k	RD½PS 224JNL
R12	Carbon film 220k	RD½PS 224JNL
R13	Carbon film 12k	RD½PS 123JNL
R14	Carbon film 12k	RD½PS 123JNL
R15	Carbon film 47k	RD½PS 473JNL
R16	Carbon film 47k	RD½PS 473JNL
R17	Carbon film 6.2k	RD½PS 622J
R18	Carbon film 6.2k	RD½PS 622J
R19	Carbon film 6.8k	RD½PS 682J
R20	Carbon film 6.8k	RD½PS 682J
R21	Carbon film 1k	RD½PS 102J
R22	Carbon film 1k	RD½PS 102J
R23	Carbon film 47k	RD½PS 473JNL
R24	Carbon film 47k	RD½PS 473JNL
R25	Carbon film 1M	RD½PS 105JNL
R26	Carbon film 1M	RD½PS 105JNL
R27	Carbon film 56k	RD½PS 563JNL

Symbol	Description	Part No.
R28	Carbon film 56k	RD½PS 563JNL
R29	Carbon film 12k	RD½PS 123JNL
R30	Carbon film 12k	RD½PS 123JNL
R31	Carbon film 3.9k	RD½PS 392J
R32	Carbon film 3.9k	RD½PS 392J
R33	Carbon film 22k	RD½PS 223J
R34	Carbon film 22k	RD½PS 223J
R35	Carbon film 27k	RD½PS 273J
R36	Carbon film 27k	RD½PS 273J
R39	Carbon film 47k	RD½PS 473J
R40	Carbon film 47k	RD½PS 473J
R41	Carbon film 1.5k	RD½PS 152J
R42	Carbon film 1.5k	RD½PS 152J
R43	Carbon film 120k	RD½PS 124J
R44	Carbon film 120k	RD½PS 124J
R45	Carbon film 10k	RD½PS 103J
R46	Carbon film 10k	RD½PS 103J
R47	Carbon film 22k	RD½PS 223J
R48	Carbon film 22k	RD½PS 223J
R49	Carbon film 680	RD½PS 681J
VR1	Variable 100k-HB (BALANCE)	ACV-163
VR2	Variable 50k-B1 (VOLUME)	ACV-164

CAPACITORS

Symbol	Description	Part No.
C1	Electrolytic (NL) 2.2 50V	CEANL 2R2P 50
C2	Electrolytic (NL) 2.2 50V	CEANL 2R2P 50
C3	Ceramic 100p 50V	CCDSL 101K 50
C4	Ceramic 100p 50V	CCDSL 101K 50
C5	Electrolytic (NL) 4.7 50V	CEANL 4R7P 50
C6	Electrolytic (NL) 4.7 50V	CEANL 4R7P 50
C7	Ceramic 470p 50V	CCDSL 471K 50
C8	Ceramic 470p 50V	CCDSL 471K 50
C9	Mylar 0.082 50V	CQMA 823J 50
C10	Mylar 0.082 50V	CQMA 823J 50
C11	Mylar 0.1 50V	CQMA 104K 50
C12	Mylar 0.1 50V	CQMA 104K 50
C13	Electrolytic 220 35V	CEA 221P 35
C14	Electrolytic 220 35V	CEA 221P 35
C15	Ceramic 47p 50V	CCDSL 470K 50
C16	Ceramic 47p 50V	CCDSL 470K 50
C17	Electrolytic 10 25V	CSZA 100P 25
C18	Electrolytic 10 25V	CEZA 100P 25
C19	Ceramic 47p 50V	CCDSL 470K 50
C20	Ceramic 47p 50V	CCESL 470K 50

Symbol	Description	Part No.
C21	Ceramic 10p 50V	CCDSL 100K 50
C22	Ceramic 10p 50V	CCDSL 100K 50
C23	Electrolytic (NL) 4.7 50V	CEANL 4R7P 50
C24	Electrolytic (NL) 4.7 50V	CEANL 4R7P 50
C25	Electrolytic (NL) 100 10V	CEANL 101P 10
C26	Electrolytic (NL) 100 10V	CEANL 101P 10
C27	Electrolytic 100 50V	CEA 101P 50

OTHERS

Symbol	Description	Part No.
	Union nut	ABN-021
	Washer faced nut	ABN-024
	Screw	ABA-116

12.9 SWITCH ASSEMBLY (AWS-093)

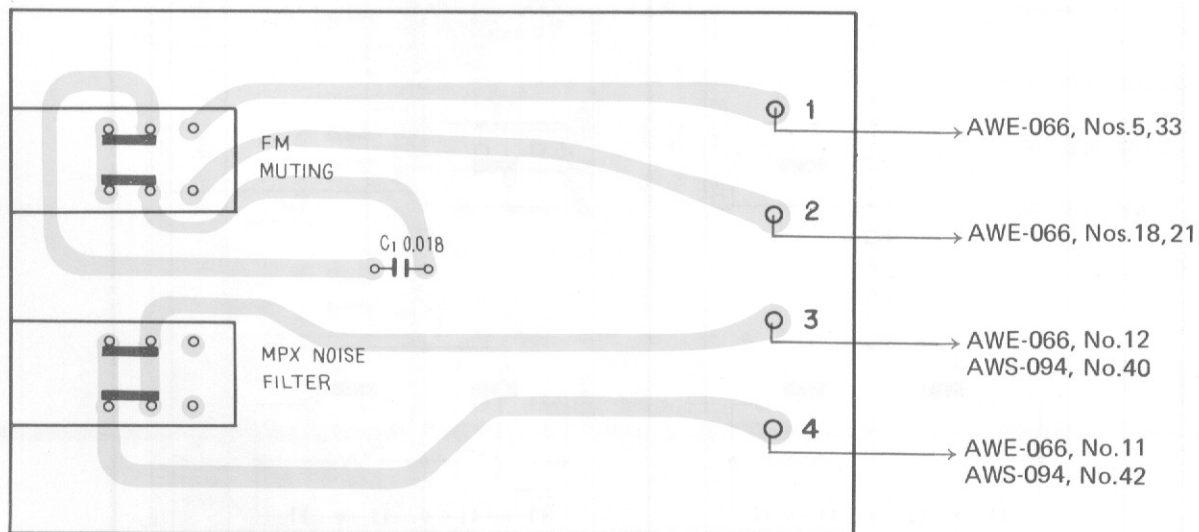
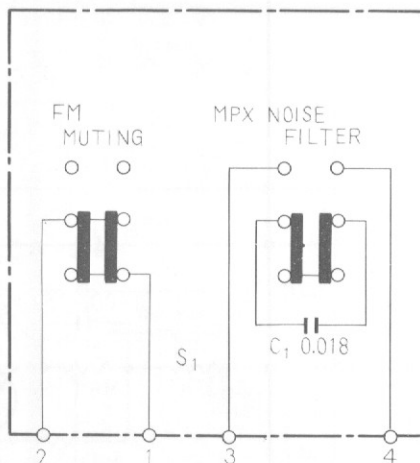

Parts List of Switch Assembly (AWS-093)

Symbol	Description	Part No.
S1	Push switch (FM MUTING, MPX NOISE FILTER)	ASG-096
C1	Mylar capacitor 0.018 50V	CQMA 183J 50

12.10 TONE AMPLIFIER ASSEMBLY (AWG-039)

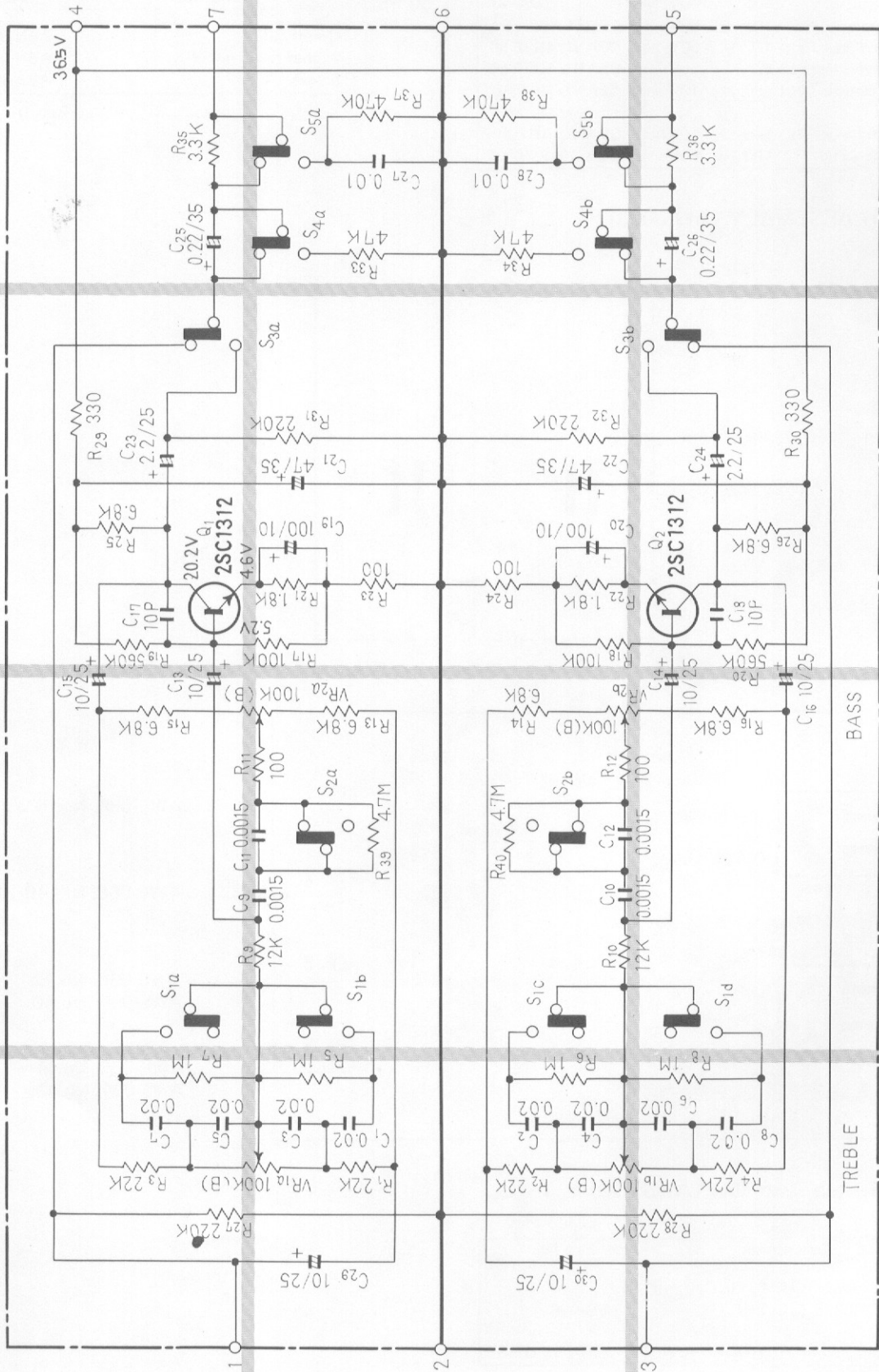

A

A

B

B

C

C

D

D

BASS

TREBLE

1

2

3

1

2

3

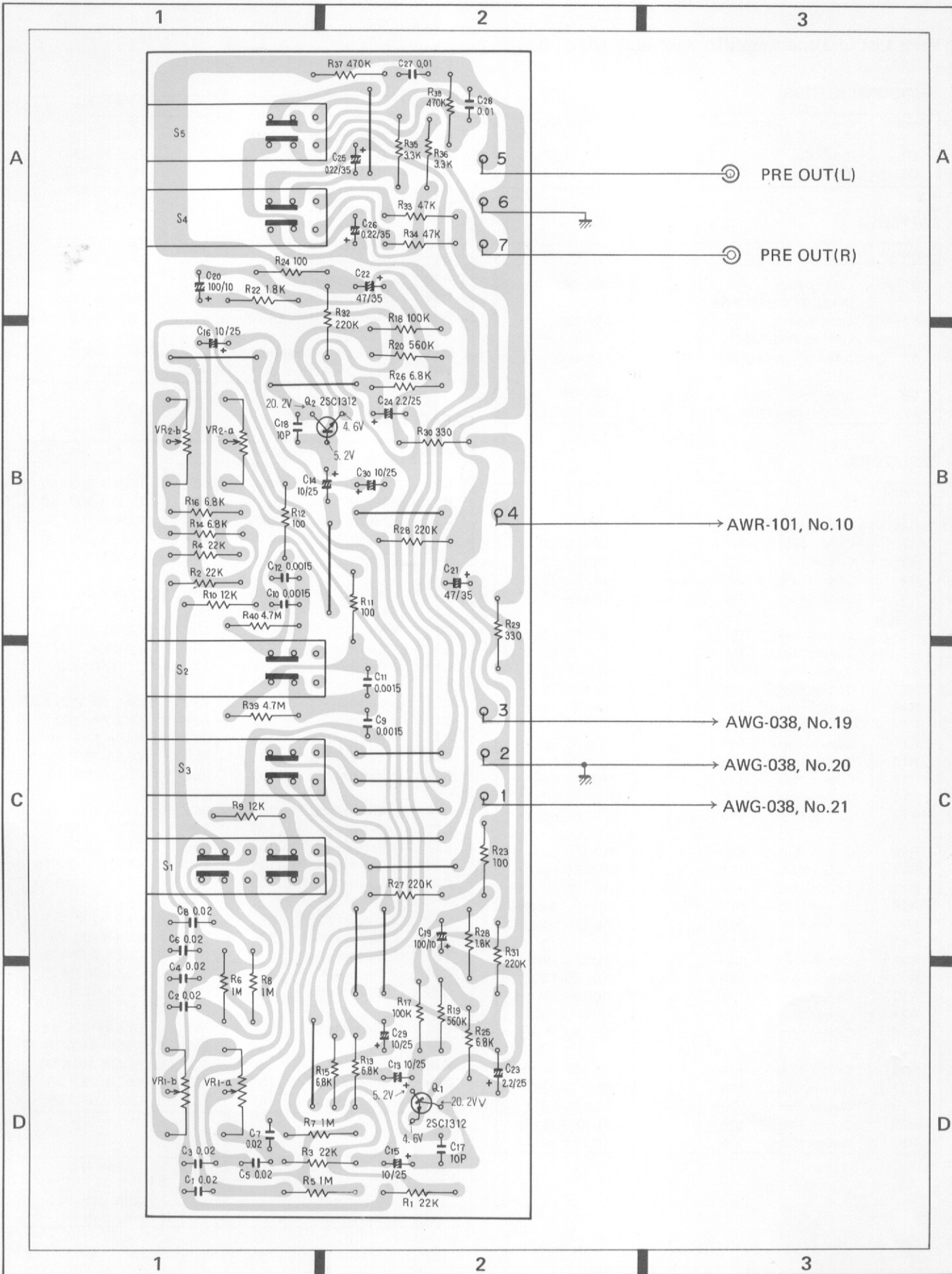

Parts List of Tone Amplifier Assembly (AWG-039)

SEMICONDUCTORS

Symbol	Description	Part No.
Q1	Transistor	2SC1312-F
Q2	Transistor	2SC1312-F

SWITCHES

Symbol	Description	Part No.
S1	Lever switch (BASS TURN-OVER)	ASK-091
S2	Lever switch (TREBLE TURN-OVER)	ASK-089
S3	Lever switch (TONE)	ASK-090
S4	Lever switch (LOW FILTER)	ASK-089
S5	Lever switch (HIGH FILTER)	ASK-089

RESISTORS

Symbol	Description	Part No.
R1	Carbon film 22k	RD½PS 223J
R2	Carbon film 22k	RD½PS 223J
R3	Carbon film 22k	RD½PS 223J
R4	Carbon film 22k	RD½PS 223J
R5	Carbon film 1M	RD½PS 105J
R6	Carbon film 1M	RD½PS 105J
R7	Carbon film 1M	RD½PS 105J
R8	Carbon film 1M	RD½PS 105J
R9	Carbon film 12k	RD½PS 123J
R10	Carbon film 12k	RD½PS 123J
R11	Carbon film 100	RD½PS 101J
R12	Carbon film 100	RD½PS 101J
R13	Carbon film 6.8k	RD½PS 682J
R14	Carbon film 6.8k	RD½PS 682J
R15	Carbon film 6.8k	RD½PS 682J
R16	Carbon film 6.8k	RD½PS 682J
R17	Carbon film 100k	RD½PS 104JNL
R18	Carbon film 100k	RD½PS 104JNL
R19	Carbon film 560k	RD½PS 564JNL
R20	Carbon film 560k	RD½PS 564JNL
R21	Carbon film 1.8k	RD½PS 182J
R22	Carbon film 1.8k	RD½PS 182J
R23	Carbon film 100	RD½PS 101J
R24	Carbon film 100	RD½PS 101J
R25	Carbon film 6.8k	RD½PS 682J
R26	Carbon film 6.8k	RD½PS 682J
R27	Carbon film 220k	RD½PS 224J
R28	Carbon film 220k	RD½PS 224J
R29	Carbon film 330	RD½PS 331J
R30	Carbon film 330	RD½PS 331J

Symbol	Description	Part No.
R31	Carbon film 220k	RD½PS 224J
R32	Carbon film 220k	RD½PS 224J
R33	Carbon film 47k	RD½PS 473J
R34	Carbon film 47k	RD½PS 473J
R35	Carbon film 3.3k	RD½PS 332J
R36	Carbon film 3.3k	RD½PS 332J
R37	Carbon film 470k	RD½PS 474J
R38	Carbon film 470k	RD½PS 474J
R39	Carbon film 4.7M	RD½PS 475J
R40	Carbon film 4.7M	RD½PS 475J
VR1	Variable 100k-B dual (BASS)	ACV-136
VR2	Variable 100k-B dual (TREBLE)	ACV-136

CAPACITORS

Symbol	Description	Part No.
C1	Mylar 0.02 50V	CQMA 203J 50
C2	Mylar 0.02 50V	CQMA 203J 50
C3	Mylar 0.02 50V	CQMA 203J 50
C4	Mylar 0.02 50V	CQMA 203J 50
C5	Mylar 0.02 50V	CQMA 203J 50
C6	Mylar 0.02 50V	CQMA 203J 50
C7	Mylar 0.02 50V	CQMA 203J 50
C8	Mylar 0.02 50V	CQMS 203J 50
C9	Ceramic 0.0015 50V	CKDYA 152J 50
C10	Ceramic 0.0015 50V	CKDYA 152J 50
C11	Ceramic 0.0015 50V	CKDYA 152J 50
C12	Ceramic 0.0015 50V	CKDYA 152J 50
C13	Electrolytic 10 25V	CSZA 100P 25
C14	Electrolytic 10 25V	CSZA 100P 25
C15	Electrolytic 10 25V	CSZA 100P 25
C16	Electrolytic 10 25V	CSZA 100P 25
C17	Ceramic 10p 50V	CCDSL 100K 50
C18	Ceramic 10p 50V	CCDSL 100K 50
C19	Electrolytic (NL) 100 16V	CEANL 101P 10
C20	Electrolytic (NL) 100 16V	CEANL 101P 10
C21	Electrolytic 47 35V	CEA 470P 35
C22	Electrolytic 47 35V	CEA 470P 35
C23	Electrolytic 2.2 25V	CSZA 2R2M 25
C24	Electrolytic 2.2 25V	CSZA 2R2M 25
C25	Electrolytic 0.22 35V	CSZA R22K 35
C26	Electrolytic 0.22 35V	CSZA R22K 35
C27	Mylar 0.01 50V	CQMA 103K 50
C28	Mylar 0.01 50V	CQMA 103K 50
C29	Electrolytic 10 25V	CSZA 100P 25
C30	Electrolytic 10 25V	CSZA 100P 25

OTHERS

Symbol	Description	Part No.
	Union nut	ABN-021
	Screw	ABA-116

12.11 SWITCH ASSEMBLY (AWX-095)

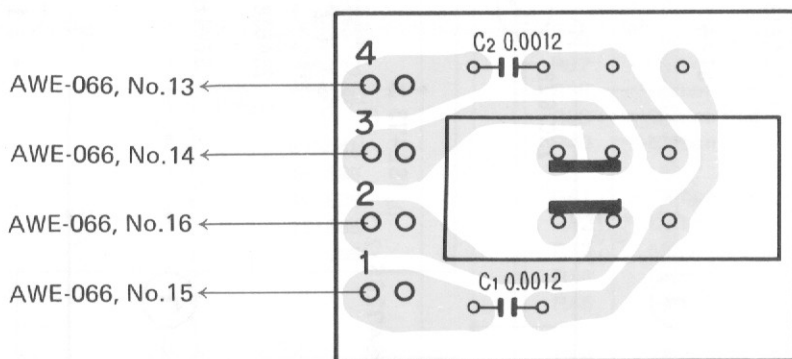
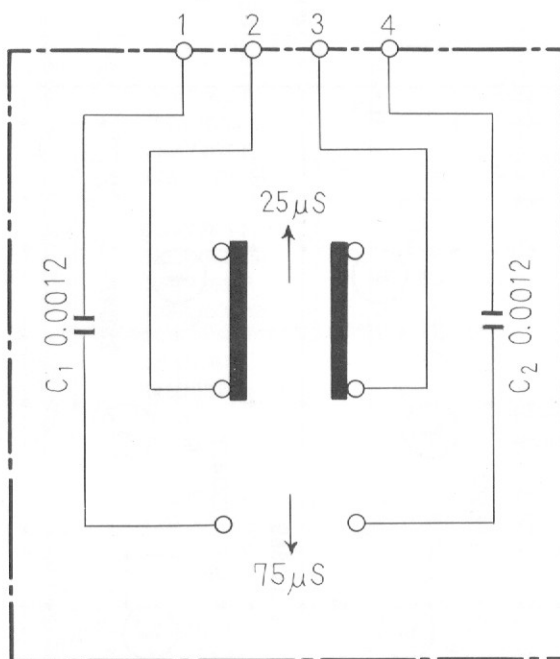

Parts List of Switch Assembly (AWX-095)

Symbol	Description	Part No.
	Slide switch (DE-EMPHASIS)	ASH-015
C1	Mylar capacitor 0.0012 50V	CQMA 122J 50
C2	Mylar capacitor 0.0012 50V	CQMA 122J 50

12.12 POWER AMPLIFIER ASSEMBLY (AWH-050)

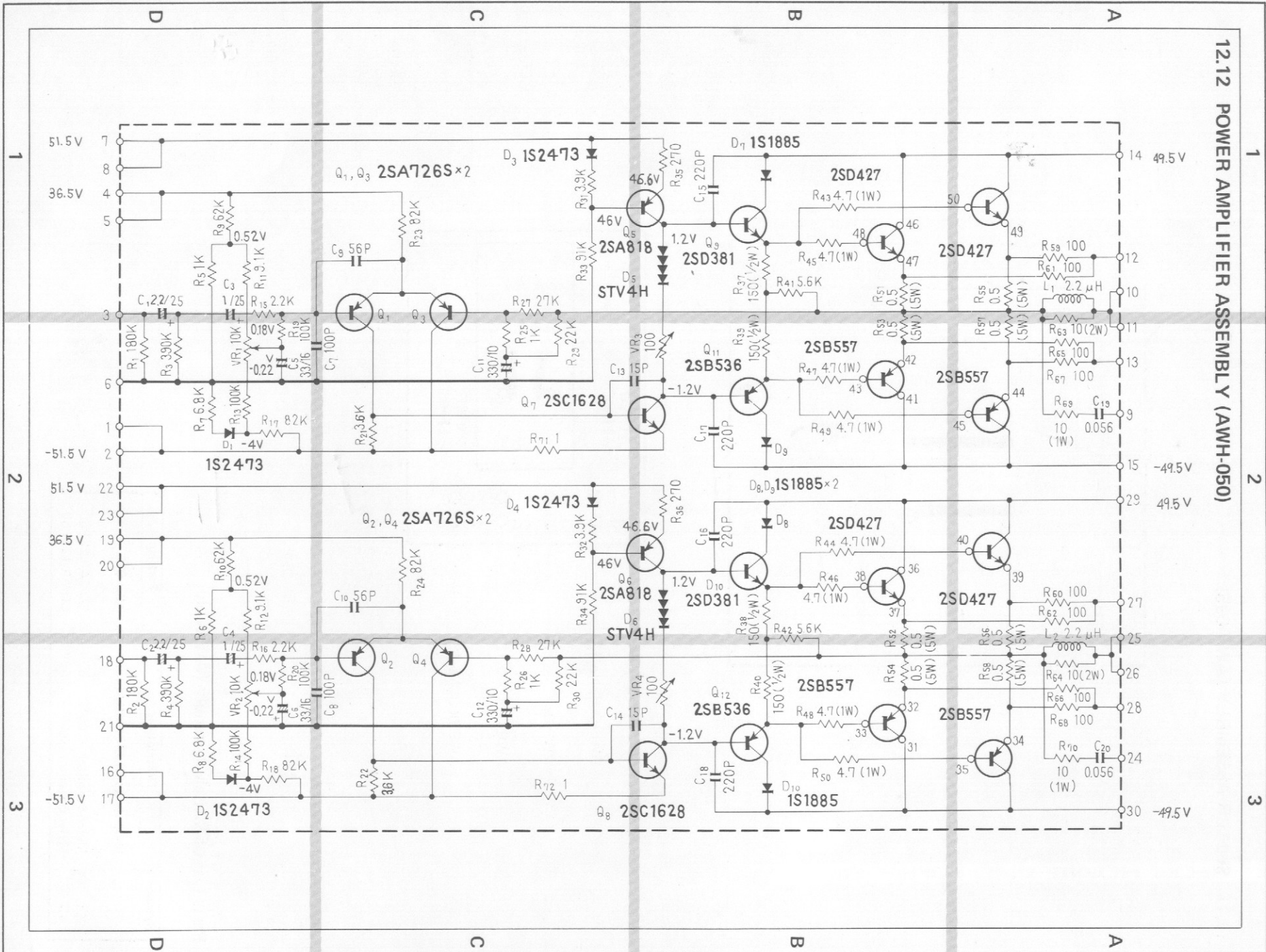

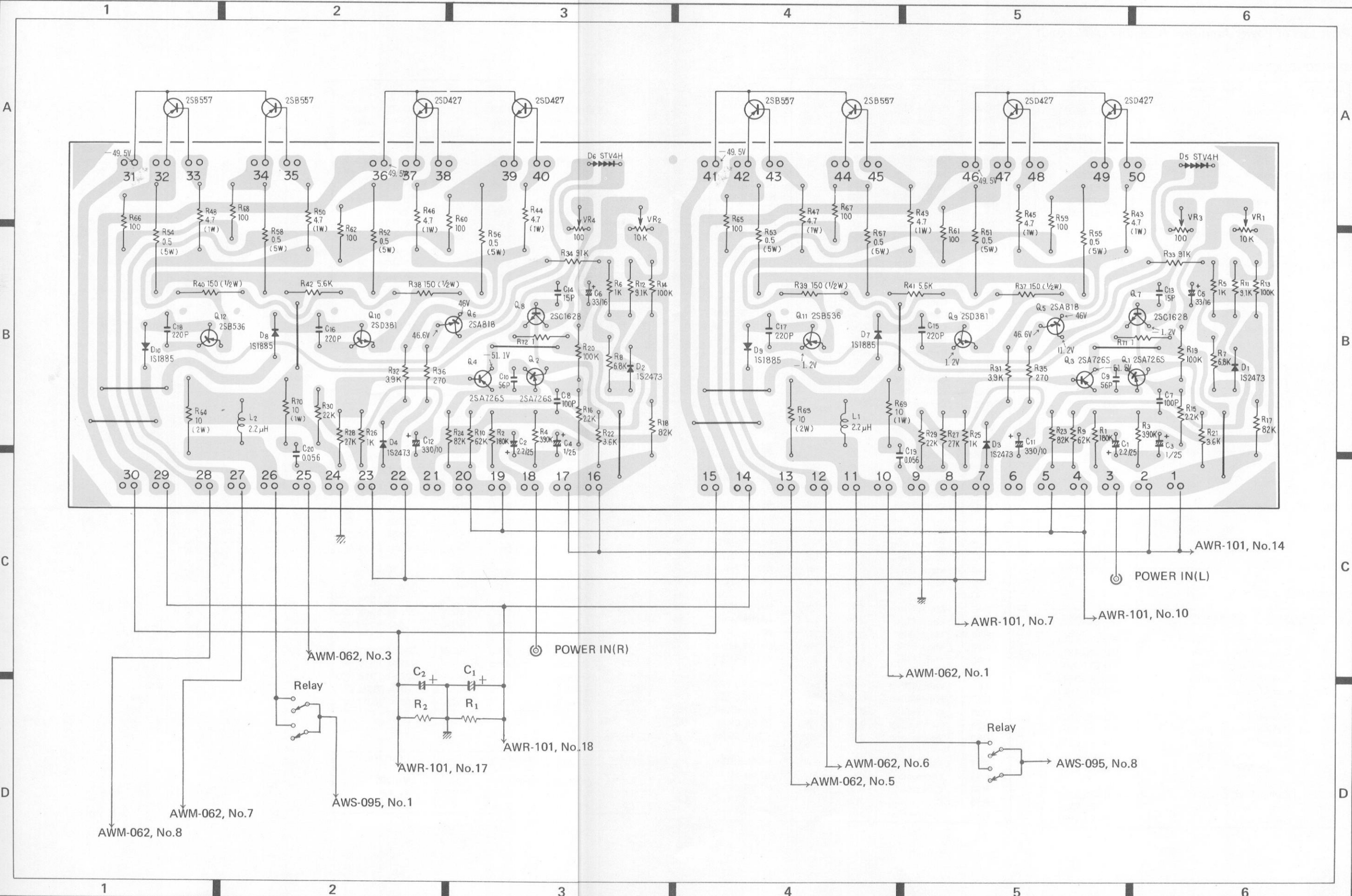

AWM-062, No.8

AWM-062, No.7

AWS-095, No.1

Relay

AWM-062, No.3

POWER IN(R)

AWR-101, No.17

AWR-101, No.18

AWR-101, No.7

POWER IN(L)

AWR-101, No.10

AWM-062, No.1

AWM-062, No.5

AWM-062, No.6

Relay

AWS-095, No.8

Parts List of Power Amplifier Assembly (AWH-050)

SEMICONDUCTORS

Symbol	Description	Part No.
Q1	Transistor	2SA726S-F (2SA763S-5)
Q2	Transistor	2SA726S-F (2SA763S-5)
Q3	Transistor	2SA726S-F (2SA763S-5)
Q4	Transistor	2SA726S-F (2SA763S-5)
Q5	Transistor	2SA818-Y (2SB527-C)
Q6	Transistor	2SA818-Y (2SB527-C)
Q7	Transistor	2SC1628-Y (2SC1451-B)
Q8	Transistor	2SC1628-Y (2SC1451-B)
Q9	Transistor	2SD381-M
Q10	Transistor	2SD381-M
Q11	Transistor	2SB536-M
Q12	Transistor	2SB536-M
D1	Diode	1S2473
D2	Diode	1S2473
D3	Diode	1S2473
D4	Diode	1S2473
D5	Varistor	STV-4H
D6	Varistor	STV-4H
D7	Diode	1S1885
D8	Diode	1S1885
D9	Diode	1S1885
D10	Diode	1S1885

RESISTORS

Symbol	Description	Part No.
R1	Carbon film 180k	RD½PS 184J
R2	Carbon film 180k	RD½PS 184J
R3	Carbon film 390k	RD½PS 394J
R4	Carbon film 390k	RD½PS 394J
R5	Carbon film 1k	RD½PS 102J
R6	Carbon film 1k	RD½PS 102J
R7	Carbon film 6.8k	RD½PS 682J
R8	Carbon film 6.8k	RD½PS 682J
R9	Carbon film 62k	RD½PS 623J
R10	Carbon film 62k	RD½PS 623J
R11	Carbon film 9.1k	RD½PS 912J
R12	Carbon film 9.1k	RD½PS 912J
R13	Carbon film 100k	RD½PS 104J

Symbol	Description	Part No.
R14	Carbon film 100k	RD½PS 104J
R15	Carbon film 2.2k	RD½PS 222J
R16	Carbon film 2.2k	RD½PS 222J
R17	Carbon film 82k	RD½PS 823J
R18	Carbon film 82k	RD½PS 823J
R19	Carbon film 100k	RD½PS 104J
R20	Carbon film 100k	RD½PS 104J
R21	Carbon film 3.6k	RD½PS 362J
R22	Carbon film 3.6k	RD½PS 362J
R23	Carbon film 82k	RD½PS 823J
R24	Carbon film 82k	RD½PS 823J
R25	Carbon film 1k	RD½PS 102J
R26	Carbon film 1k	RD½PS 102J
R27	Carbon film 27k	RD½PS 273J
R28	Carbon film 27k	RD½PS 273J
R29	Carbon film 22k	RD½PS 223J
R30	Carbon film 22k	RD½PS 223J
R31	Carbon film 3.9k	RD½PS 392J
R32	Carbon film 3.9k	RD½PS 392J
R33	Carbon film 91k	RD½PS 913J
R34	Carbon film 91k	RD½PS 913J
R35	Carbon film 270	RD½PS 271J
R36	Carbon film 270	RD½PS 271J
R37	Carbon film 150 ½W	RD½PS 151J
R38	Carbon film 150 ½W	RD½PS 151J
R39	Carbon film 150 ½W	RD½PS 151J
R40	Carbon film 150 ½W	RD½PS 151J
R41	Carbon film 5.6k	RD½PS 562J
R42	Carbon film 5.6k	RD½PS 562J
R43	Metal film 4.7 1W	RN1H 4R7K
R44	Metal film 4.7 1W	RN1H 4R7K
R45	Metal film 4.7 1W	RN1H 4R7K
R46	Metal film 4.7 1W	RN1H 4R7K
R47	Metal film 4.7 1W	RN1H 4R7K
R48	Metal film 4.7 1W	RN1H 4R7K
R49	Metal film 4.7 1W	RN1H 4R7K
R50	Metal film 4.7 1W	RN1H 4R7K
R51	Wire wound 0.5 5W	RT5B 0R5K
R52	Wire wound 0.5 5W	RT5B 0R5K
R53	Wire wound 0.5 5W	RT5B 0R5K
R54	Wire wound 0.5 5W	RT5B 0R5K
R55	Wire wound 0.5 5W	RT5B 0R5K
R56	Wire wound 0.5 5W	RT5B 0R5K
R57	Wire wound 0.5 5W	RT5B 0R5K
R58	Wire wound 0.5 5W	RT5B 0R5K
R59	Carbon film 100	RD½PS 101J
R60	Carbon film 100	RD½PS 101J

Symbol	Description			Part No.
R61	Carbon film	100		RD¼PS 101J
R62	Carbon film	100		RD¼PS 101J
R63	Metal oxide	10	2W	RS2P 100J
R64	Metal oxide	10	2W	RS2P 100J
R65	Carbon film	100		RD¼PS 101J
R66	Carbon film	100		RD¼PS 101J
R67	Carbon film	100		RD¼PS 101J
R68	Carbon film	100		RD¼PS 101J
R69	Metal oxide	10	1W	RS1P 100J
R70	Metal oxide	10	1W	RS1P 100J
R71	Carbon film	1		RD¼PS 010J
R72	Carbon film	1		RD¼PS 010J
VR1	Semi-fixed	1k-B		ACP-029
VR2	Semi-fixed	1k-B		ACP-029
VR3	Semi-fixed	100-B		ACP-019
VR4	Semi-fixed	100-B		ACP-019

CAPACITORS

Symbol	Description			Part No.
C1	Electrolytic	2.2	25V	CSSA 2R2M 25
C2	Electrolytic	2.2	25V	CSSA 2R2M 25
C3	Electrolytic	1	25V	CSSA 010M 25
C4	Electrolytic	1	25V	CSSA 010M 25
C5	Electrolytic	33	16V	CEA 330P 16
C6	Electrolytic	33	16V	CEA 330P 16
C7	Ceramic	100p	50V	CCDSL 101K 50
C8	Ceramic	100p	50V	CCDSL 101K 50
C9	Ceramic	56p	50V	CCDSL 560K 50
C10	Ceramic	56p	50V	CCDSL 560K 50
C11	Electrolytic	330	10V	CEA 331P 10
C12	Electrolytic	330	10V	CEA 331P 10
C13	Ceramic	15p	500V	CCDSL 150K 500
C14	Ceramic	15p	500V	CCDSL 150K 500
C15	Ceramic	220p	500V	CCDSL 221K 500
C16	Ceramic	220p	500V	CCDSL 221K 500
C17	Ceramic	220p	500V	CCDSL 221K 500
C18	Ceramic	220p	500V	CCDSL 221K 500
C19	Mylar	0.056	50V	CQMA 563M 50
C20	Mylar	0.056	50V	CQMA 563M 50

OTHERS

Symbol	Description		Part No.
	Heat sink (small)		ANH-203
L1	AF choke coil	2.2µH	T63-009
L2	AF choke coil	2.2µH	T63-009

12.13 PROTECTION CIRCUIT ASSEMBLY (AWM-062)

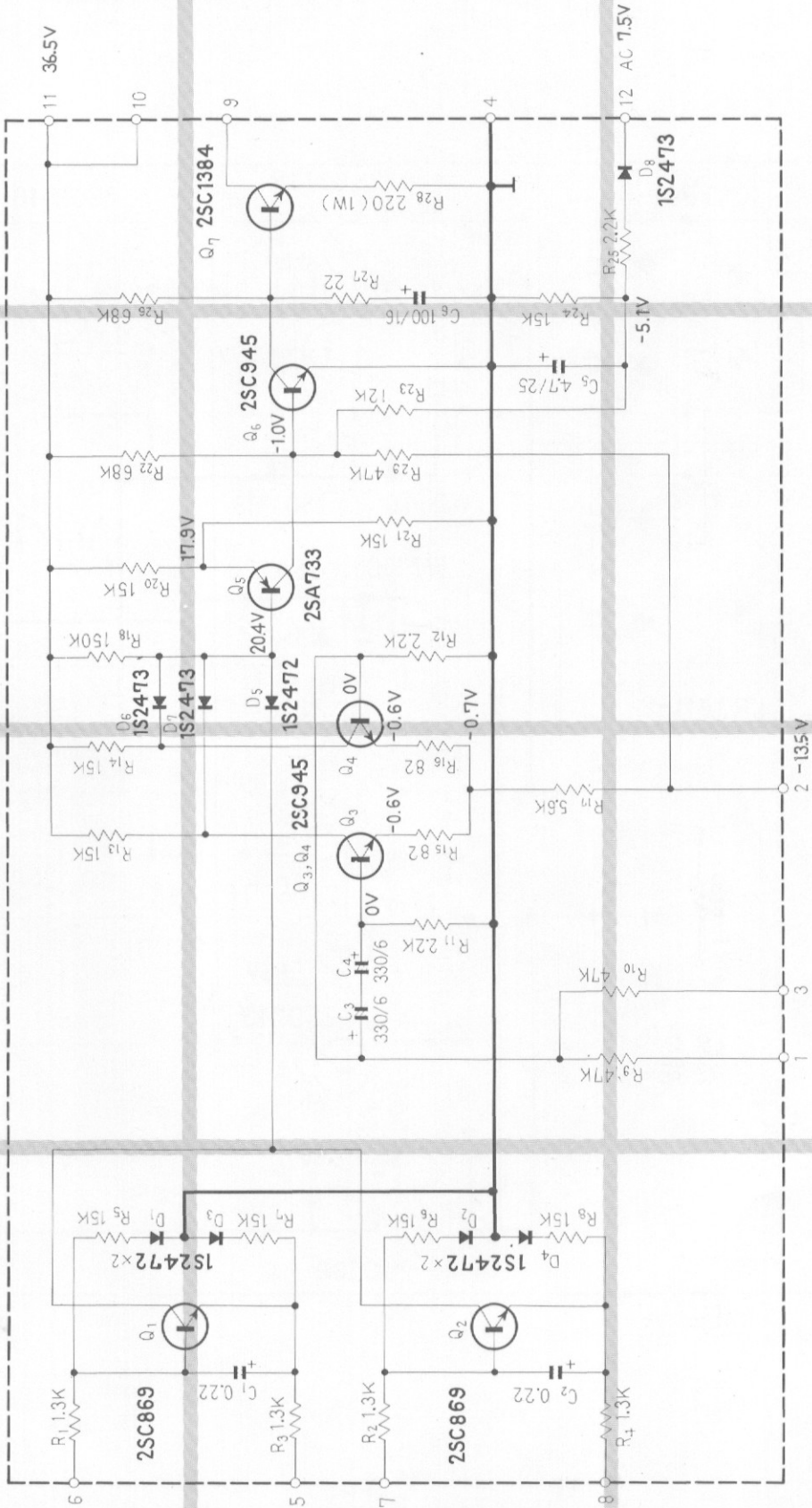

1 2 3

A

A

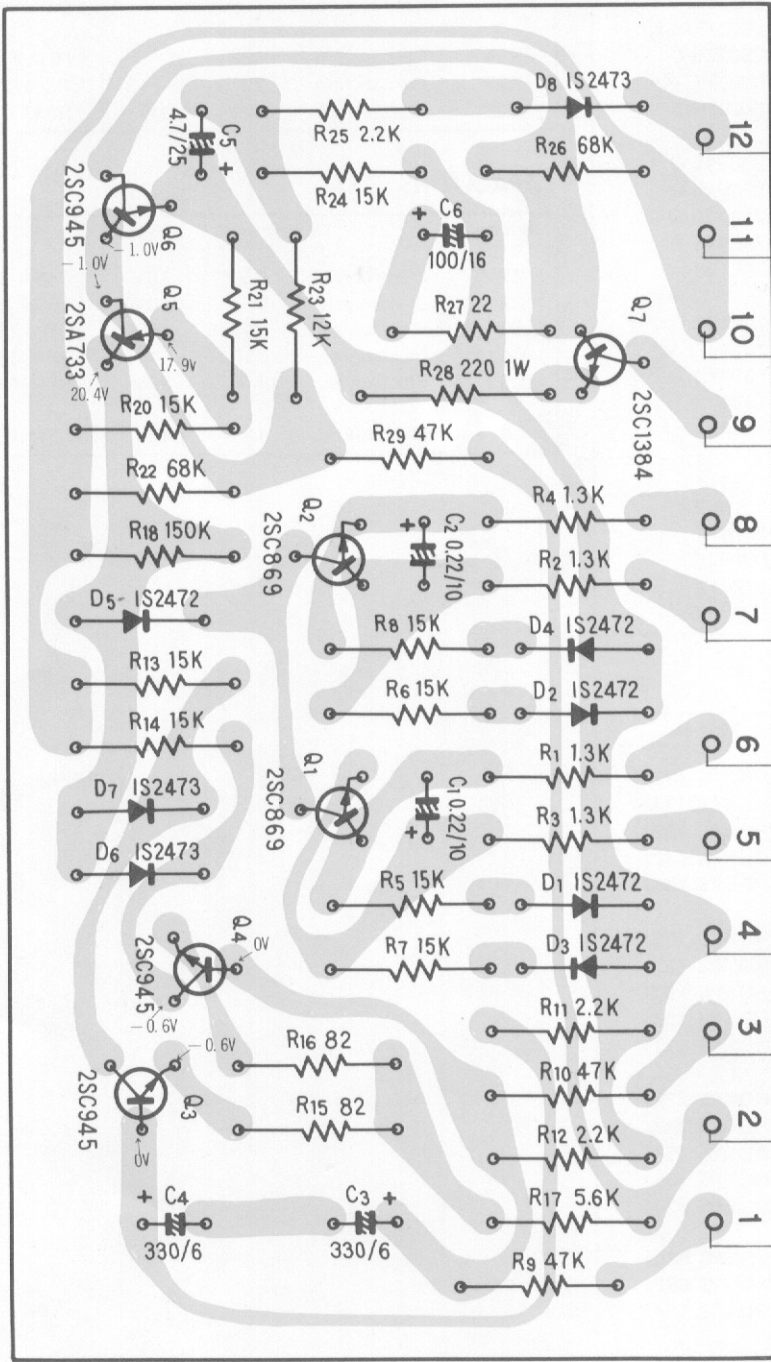

12 → AWR-101, No.23

11 →

10 → AWR-101, No.10

9 → Relay coil

8 → AWH-050, No.28

7 → AWH-050, No.27

6 → AWH-050, No.12

5 → AWH-050, No.13

4 →

3 → AWH-050, No.25

2 → AWR-101, No.13

1 → AWH-050, No.10

B

B

C

C

D

D

1 2 3

Parts List of Protection Circuit Assembly (AWM-062)

SEMICONDUCTORS

Symbol	Description	Part No.
Q1	Transistor	2SC869-C (2SC857-K) (2SC1515-K)
Q2	Transistor	2SC869-C (2SC857-K) (2SC1515-K)
Q3	Transistor	2SC945-Q
Q4	Transistor	2SC945-Q
Q5	Transistor	2SA733-Q
Q6	Transistor	2SC945-Q
Q7	Transistor	2SC1384-R
D1	Diode	1S2472
D2	Diode	1S2472
D3	Diode	1S2472
D4	Diode	1S2472
D5	Diode	1S2472
D6	Diode	1S2473 (1S1555)
D7	Diode	1S2473 (1S1555)
D8	Diode	1S2473 (1S1555)

Symbol	Description	Part No.
R24	Carbon film 15k	RD¼PS 153J
R25	Carbon film 2.2k	RD¼PS 222J
R26	Carbon film 68k	RD¼PS 683J
R27	Carbon film 22	RD¼PS 220J
R28	Metal oxide 220 1W	RS1P 221J

CAPACITORS

Symbol	Description	Part No.
C1	Electrolytic 0.22 10V	CSSA R22M 10
C2	Electrolytic 0.22 10V	CSSA R22M 10
C3	Electrolytic 330 6V	CEA 331P 6
C4	Electrolytic 330 6V	CEA 331P 6
C5	Electrolytic 4.7 25V	CEA 4R7P 25
C6	Electrolytic 100 16V	CEA 101P 16

RESISTORS

Symbol	Description	Part No.
R1	Carbon film 1.3k	RD¼PS 132J
R2	Carbon film 1.3k	RD¼PS 132J
R3	Carbon film 1.3k	RD¼PS 132J
R4	Carbon film 1.3k	RD¼PS 132J
R5	Carbon film 15k	RD¼PS 153J
R6	Carbon film 15k	RD¼PS 153J
R7	Carbon film 15k	RD¼PS 153J
R8	Carbon film 15k	RD¼PS 153J
R9	Carbon film 47k	RD¼PS 473J
R10	Carbon film 47k	RD¼PS 473J
R11	Carbon film 2.2k	RD¼PS 222J
R12	Carbon film 2.2k	RD¼PS 222J
R13	Carbon film 15k	RD¼PS 153J
R14	Carbon film 15k	RD¼PS 153J
R15	Carbon film 82	RD¼PS 820J
R16	Carbon film 82	RD¼PS 820J
R17	Carbon film 5.6k	RD¼PS 562J
R18	Carbon film 150k	RD¼PS 154J
R19	Vacancy
R20	Carbon film 15k	RD¼PS 153J
R21	Carbon film 15k	RD¼PS 153J
R22	Carbon film 68k	RD¼PS 683J
R23	Carbon film 12k	RD¼PS 123J

12.14 POWER SUPPLY ASSEMBLY (AWR-101)

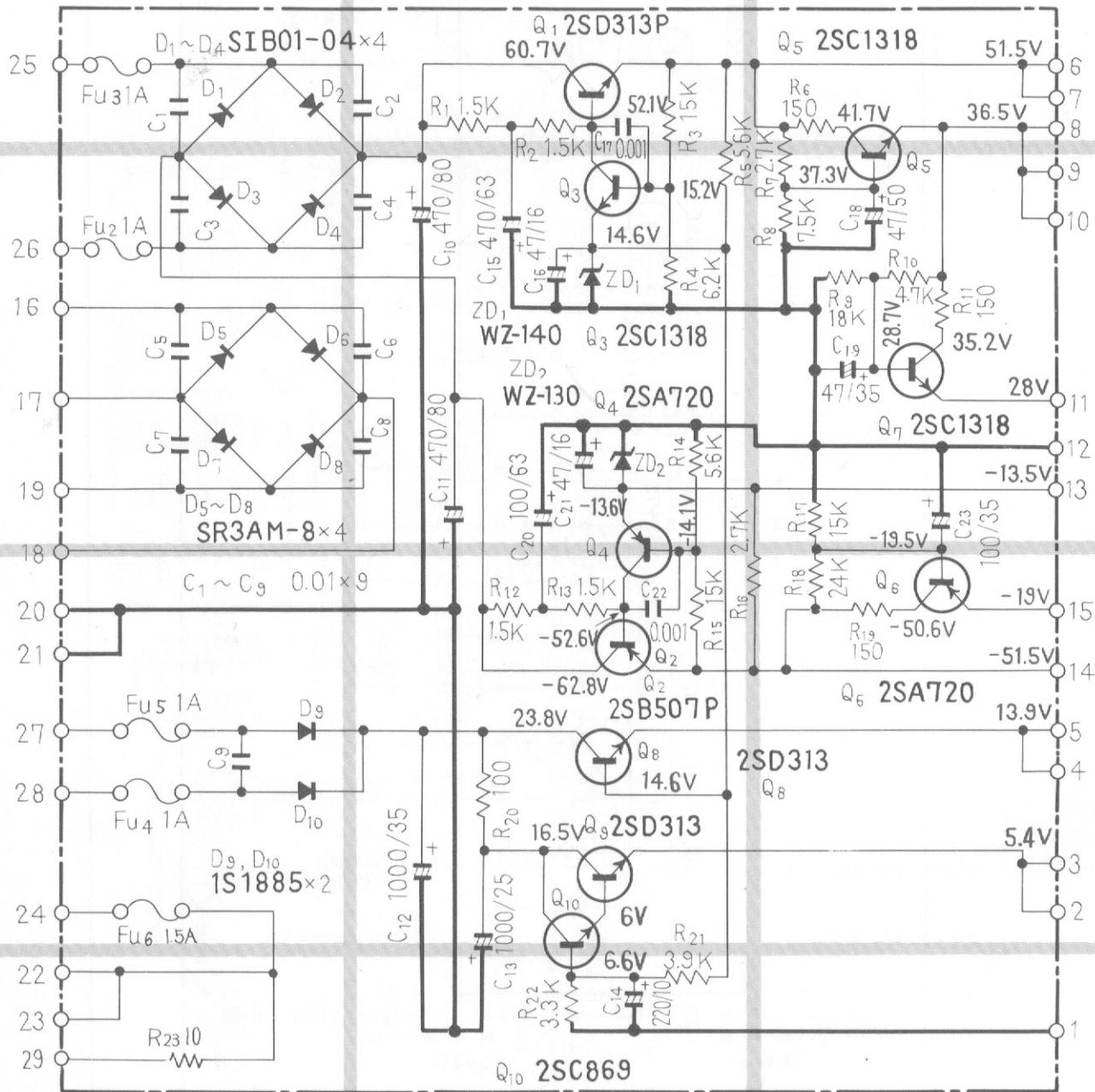

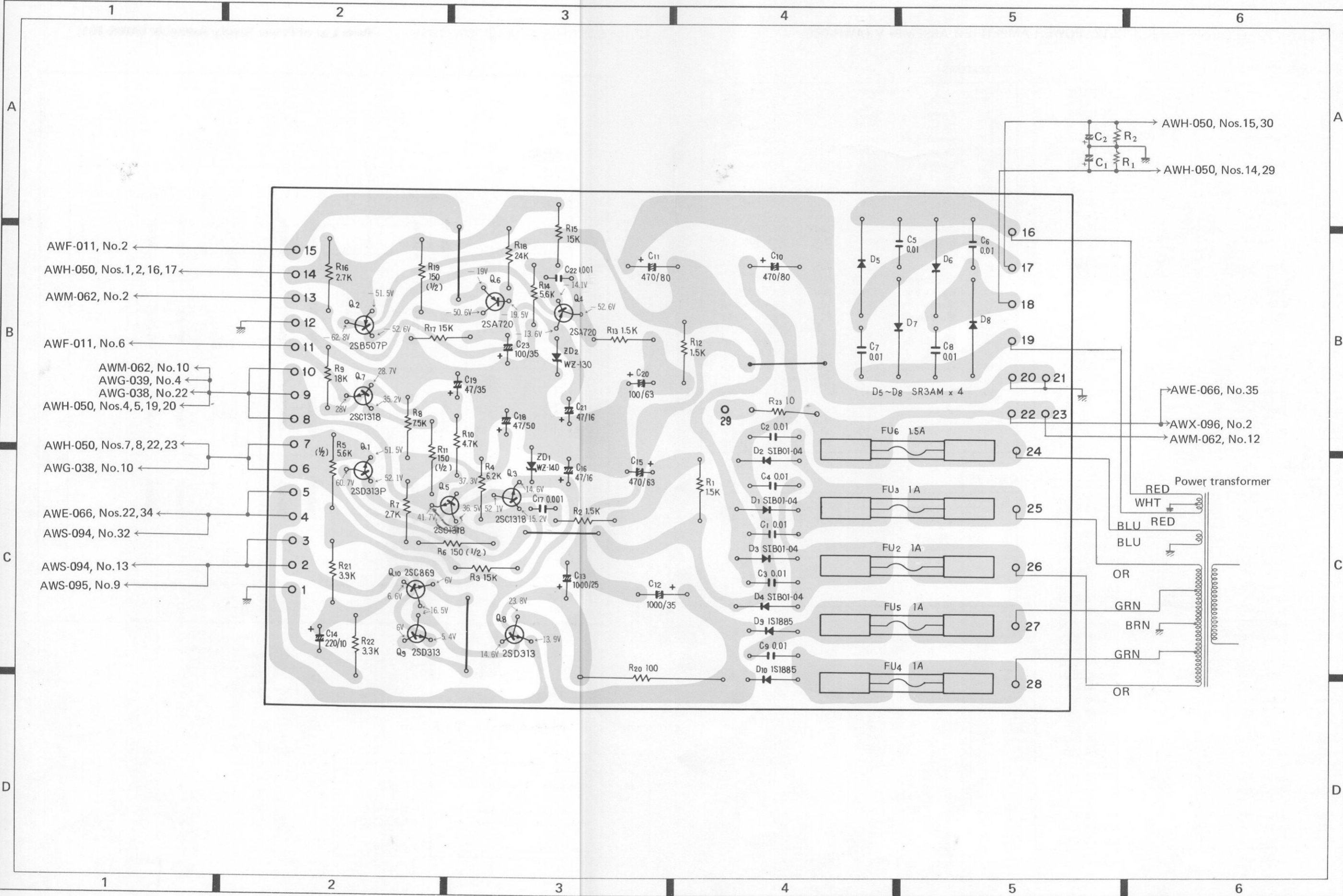

- AWF-011, No.2 ←
- AWH-050, Nos.1,2,16,17 ←
- AWM-062, No.2 ←
- AWF-011, No.6 ←
- AWM-062, No.10 ←
- AWG-039, No.4 ←
- AWG-038, No.22 ←
- AWH-050, Nos.4,5,19,20 ←
- AWH-050, Nos.7,8,22,23 ←
- AWG-038, No.10 ←
- AWE-066, Nos.22,34 ←
- AWS-094, No.32 ←
- AWS-094, No.13 ←
- AWS-095, No.9 ←

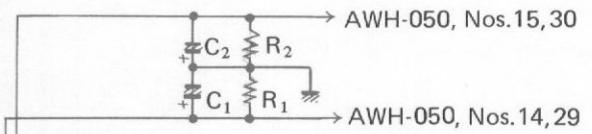

- AWE-066, No.35
- AWX-096, No.2
- AWM-062, No.12

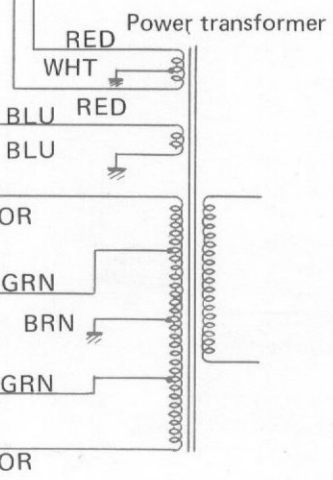

Parts List of Power Supply Assembly (AWR-101)

SEMICONDUCTORS

Symbol	Description	Part No.
Q1	Transistor	2SD313P-E
Q2	Transistor	2SB507P-E
Q3	Transistor	2SC1318-Q
Q4	Transistor	2SA720-Q
Q5	Transistor	2SC1318-Q
Q6	Transistor	2SA720-Q
Q7	Transistor	2SC1318-Q
Q8	Transistor	2SD313-E
Q9	Transistor	2SD313-E
Q10	Transistor	2SC869-C
D1	Diode	SIB01-04
D2	Diode	SIB01-04
D3	Diode	SIB01-04
D4	Diode	SIB01-04
D5	Diode	SR3AM-8
D6	Diode	SR3AM-8
D7	Diode	SR3AM-8
D8	Diode	SR3AM-8
D9	Diode	1S1885
D10	Diode	1S1885
D11	Zener diode	WZ-140
D12	Zener diode	WZ-130

CAPACITORS

Symbol	Description	Part No.
C1	Ceramic 0.01 150V	ACG-004
C2	Ceramic 0.01 150V	ACG-004
C3	Ceramic 0.01 150V	ACG-004
C4	Ceramic 0.01 150V	ACG-004
C5	Ceramic 0.01 150V	ACG-004
C6	Ceramic 0.01 150V	ACG-004
C7	Ceramic 0.01 150V	ACG-004
C8	Ceramic 0.01 150V	ACG-004
C9	Ceramic 0.01 150V	ACG-004
C10	Electrolytic 470 80V	ACH-038
C11	Electrolytic 470 80V	ACH-038
C12	Electrolytic 1,000 35V	ACH-039
C13	Electrolytic 1,000 25V	CEA 102P 25
C14	Electrolytic 220 10V	CEA 221P 10
C15	Electrolytic 470 63V	CEA 471P 63
C16	Electrolytic 47 16V	CEA 470P 16
C17	Ceramic 0.001 50V	CKDYF 102Z 50
C18	Electrolytic 47 50V	CEA 470P 50
C19	Electrolytic 47 35V	CEA 470P 35
C20	Electrolytic 100 63V	CEA 101P 63
C21	Electrolytic 47 16V	CEA 470P 16
C22	Ceramic 0.001 50V	CKDYF 102Z 50
C23	Electrolytic 100 35V	CEA 101P 35

RESISTORS

Symbol	Description	Part No.
R1	Carbon film 1.5k	RD $\frac{1}{4}$ PS 152J
R2	Carbon film 1.5k	RD $\frac{1}{4}$ PS 152J
R3	Carbon film 15k	RD $\frac{1}{4}$ PS 153J
R4	Carbon film 6.2k	RD $\frac{1}{4}$ PS 622J
R5	Carbon film 5.6k $\frac{1}{2}W$	RD $\frac{1}{2}$ PS 562J
R6	Carbon film 150 $\frac{1}{2}W$	RD $\frac{1}{2}$ PS 151J
R7	Carbon film 2.7k	RD $\frac{1}{4}$ PS 272J
R8	Carbon film 7.5k	RD $\frac{1}{4}$ PS 752J
R9	Carbon film 18k	RD $\frac{1}{4}$ PS 183J
R10	Carbon film 4.7k	RD $\frac{1}{4}$ PS 472J
R11	Carbon film 150 $\frac{1}{2}W$	RD $\frac{1}{2}$ PS 151J
R12	Carbon film 1.5k	RD $\frac{1}{4}$ PS 152J
R13	Carbon film 1.5k	RD $\frac{1}{4}$ PS 152J
R14	Carbon film 5.6k	RD $\frac{1}{4}$ PS 562J
R15	Carbon film 15k	RD $\frac{1}{4}$ PS 153J
R16	Carbon film 2.7k $\frac{1}{2}W$	RD $\frac{1}{2}$ PS 272J
R17	Carbon film 15k	RD $\frac{1}{4}$ PS 153J
R18	Carbon film 24k	RD $\frac{1}{4}$ PS 243J
R19	Carbon film 150 $\frac{1}{2}W$	RD $\frac{1}{2}$ PS 151J
R20	Metal oxide 100 3W	RS3P 101J
R21	Carbon film 3.9k	RD $\frac{1}{4}$ PS 392J
R22	Carbon film 3.3k	RD $\frac{1}{4}$ PS 332J
R23	Carbon film 10	RD $\frac{1}{4}$ PS 100J

OTHERS

Symbol	Description	Part No.
	Heat sink	ANH-117
	Heat sink	ANH-207
	Transistor socket	AKH-002
	Mica wafer	AEC-043
	Fuse clip	AKR-013
	Fuse clip	AKR-030

12.15 SWITCH ASSEMBLY (AWS-095)

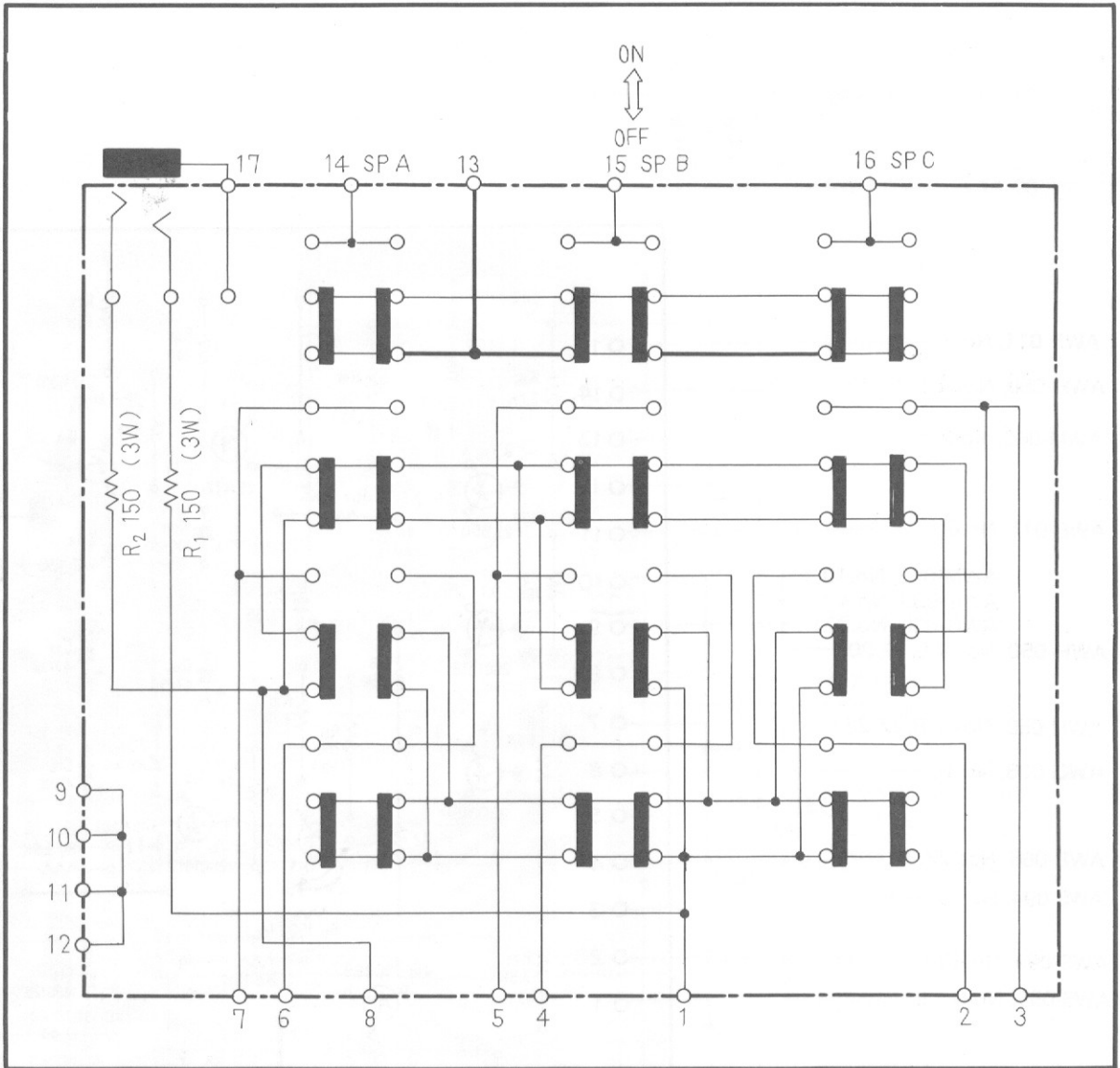

Parts List of Switch Assembly (AWS-095)

Symbol	Description	Part No.
S1	Push switch (SPEAKERS)	ASG-094
R1	Metal oxide resistor 150 3W	RS3P 151K
R2	Metal oxide resistor 150 3W	RS3P 151K
J1	Jack (PHONES)	AKN-010

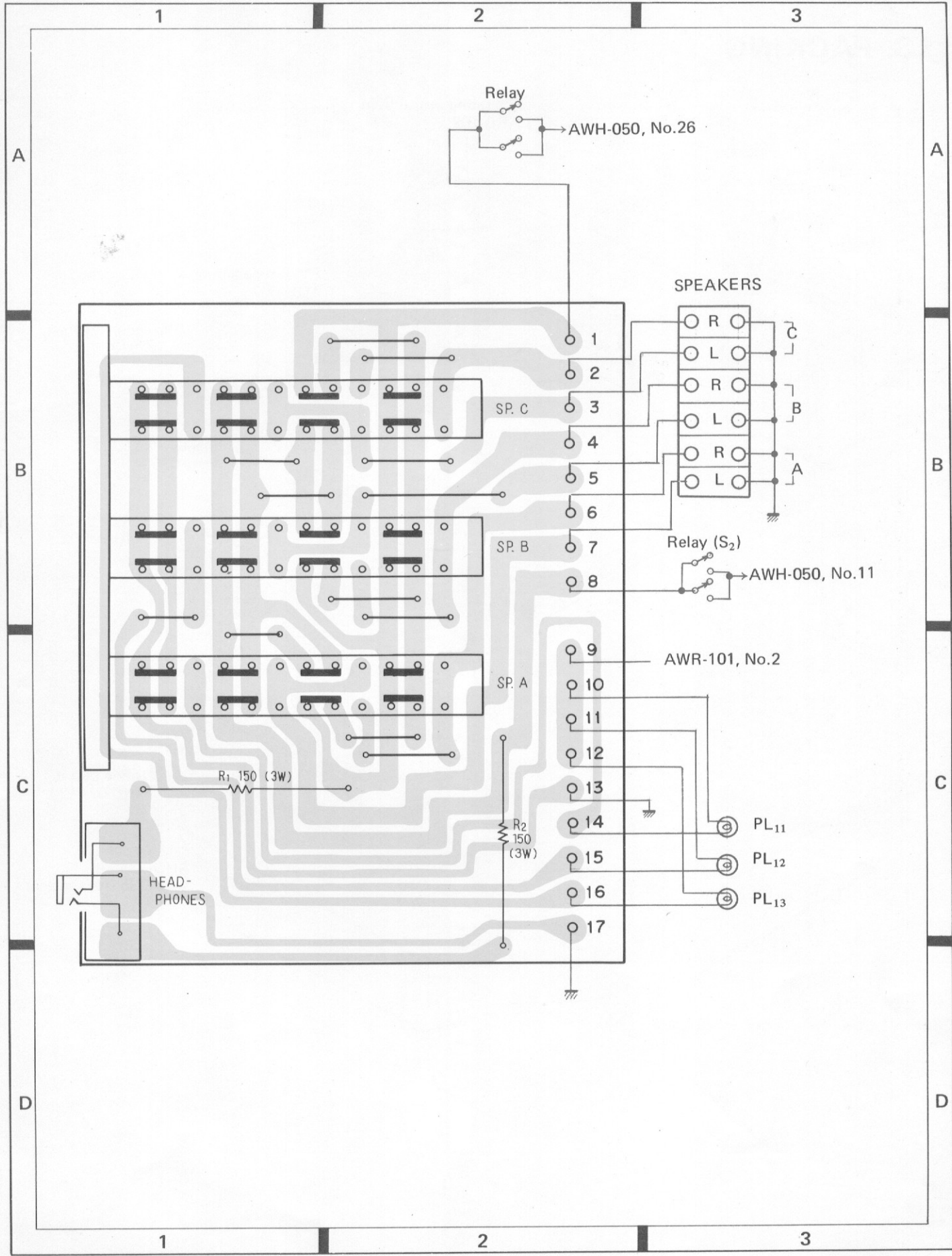

13. PACKING

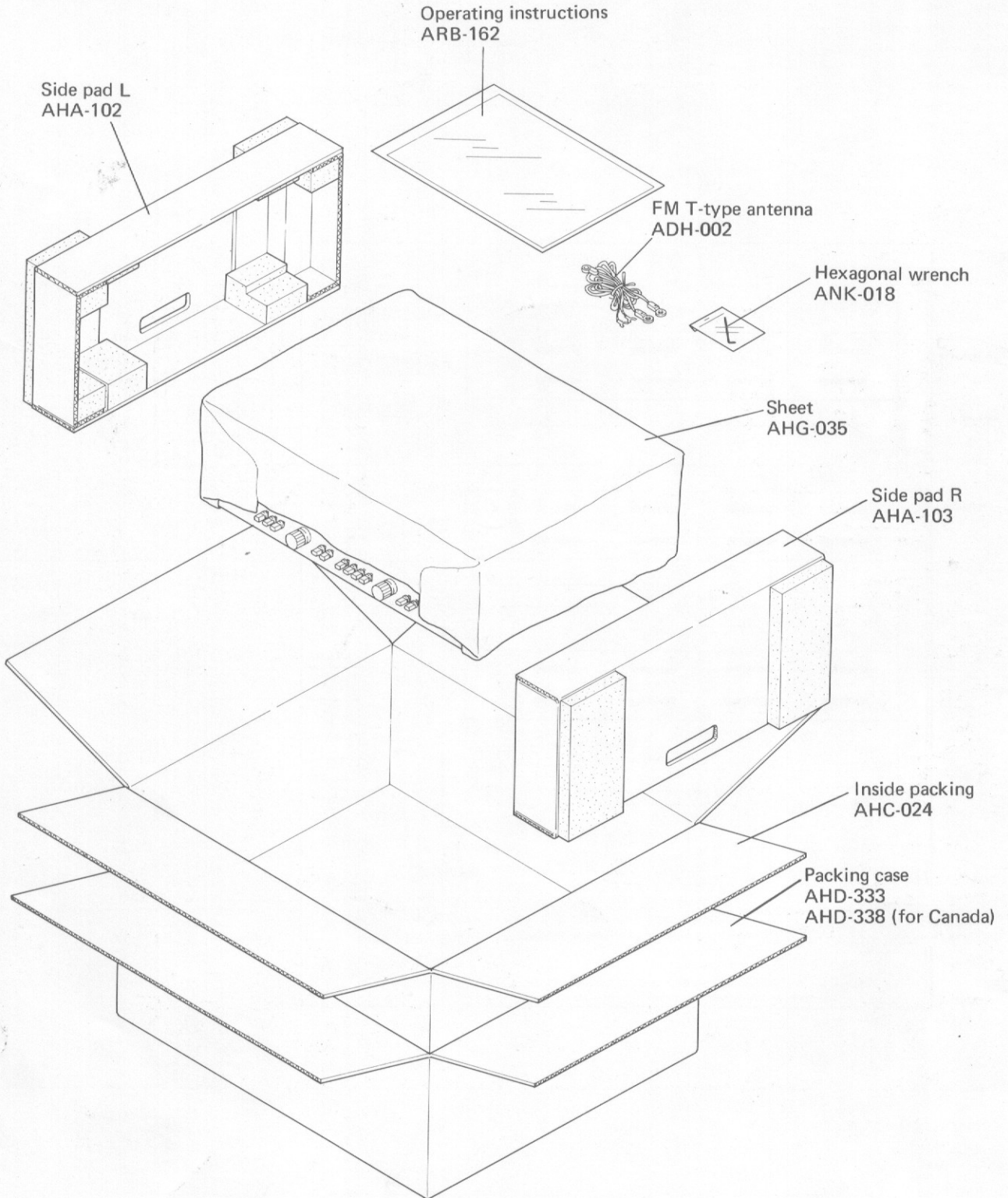

PIONEER ELECTRONIC CORPORATION

4-1, 1-Chome, Meguro, Meguro-ku, Tokyo 153, Japan

U.S. PIONEER ELECTRONICS CORPORATION

75 Oxford Drive, Moonachie, New Jersey 07074, U.S.A.

PIONEER ELECTRONIC (EUROPE) N.V.

Meir-Center Meir 21, 2000 Antwerp, Belgium

PIONEER ELECTRONICS AUSTRALIA PTY. LTD.

256-B City Road, South Melbourne, Victoria 3205, Australia

© MAY. 1975

Printed in Japan